



FULL CATALOG



THE LEADING WHOLESALE DISTRIBUTOR OF BUILDING MATERIALS IN THE MIDWEST





PRODUCT CATALOG

Welcome to our Product Catalog. We have compiled a comprehensive list of everything we stock and sell. It encompasses over 2,000 different products that are available every single day. Of course, we also have the ability to special order just about anything; if it's wood, we can source it.

We're a family-run company that's been in the wood products industry for over a hundred years, and we're currently on our third generation of family ownership and management.

Our whole philosophy is to source the best building materials in the world and provide quick and reliable access to them for any sized job, big or small.

Thank you for your support!



PAGE GUIDE

1.....7: *Introduction*

8.....20: *Engineered Wood*

21.....28: *Lumber*

29.....44: *Panels*

45.....58: *Pattern & Boards*

59.....70: *Cedar*

71.....78: *Decking*

79.....88: *Siding & Trim*

89.....90: *Concrete Forming Products*





PRODUCT BROCHURE

Oklahoma Fast Facts:

- 17 Acres and 265,000 Sq Ft of Enclosed Warehouse Space
- 13 Sales Reps, 11 Drivers, 15 Yardmen
- 11 Flatbeds, 1 Two-Ton Truck
- Over 2,000 SKU's in Inventory and On Ground
- Family Owned and Operated



REMANUFACTURING FACILITY

P.E.T. SAW:

Capable of Precision End Trimming units of lumber to exact lengths.



RESAW AND PLANER:

Resize and Surface (S4S) Douglas Fir, Western Red Cedar timbers and more.

Resaw Max Size 12" x 16"

Planer Max Size 16" x 24"



Contact Your Forest Products Rep

To Get a Quote and Lead Time

OUR WEBSITE

www.fp-supply.com/oklahoma-city-resources.html



VISIT OUR WEBSITE FOR MORE INFORMATION ON ALL OF OUR PRODUCTS.

Go to www.fp-supply.com, and then go to resources and select Oklahoma City.

Here you'll have detailed access to all of our products. Every product page includes relevant information you're looking for, including available sizes, photos, videos, PDF's of installation guides, product brochures, MSDS sheets, specifier's guides, and more.

The best part is that everything is designed for the dealer to be able to share with their customers, so we don't include any pricing on these pages. Use this as a selling tool and share these product pages and links with your customers to help close sales. It's also a mobile friendly site, so you can access this on a jobsite with a smartphone or tablet. We also have access to our price pages online via a user login page. With this, you can quote jobs at all hours of the day and have quick and easy access to all of our pricing.

OUR PATTERN POSTER



Pine & Fir Patterns



1x6 White Pine Premier Car Siding #116/122 (reversible)
1x6 White Pine Classic Car Siding #116/122 (reversible)
1x6 #2 Yellow Pine Car Siding #116/122 (reversible)



1x6 White Pine Premier Nickel Gap Finesline/#122 (reversible)
1x6 White Pine Classic Nickel Gap Finesline/#122 (reversible)



1x4 White Pine Premier Edge & Center Bead/#122 (reversible)
1x6 White Pine Premier Edge & Center Bead/#122 (reversible)
1x6 White Pine Classic Edge & Center Bead/#122 (reversible)



1x6 #2 Yellow Pine #105 Drop Siding



1x6 #2 Yellow Pine #117 Novelty Siding



2x6 SPF #122 Decking



2x6 Doug Fir #122 Decking



1x6 Doug Fir #122 (reversible smooth to textured)



1x8 White Pine Premier Car Siding #116/122 (reversible)
1x8 White Pine Classic Car Siding #116/122 (reversible)



1x8 White Pine Premier Nickel Gap Finesline/#122 (reversible)
1x8 White Pine Classic Nickel Gap Finesline/#122 (reversible)



1x8 #2 Yellow Pine Shiplap Siding (original standard profile)



1x8 #2 Yellow Pine #105 Drop Siding

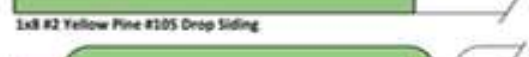

1x8 #2 Yellow Pine #131 Boston Siding

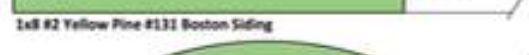

2x8 SPF Reveal Log Siding - Smooth



2x8 SPF Log-to-Log Siding - Smooth



2x8 SPF Log-to-Log Siding - Hand Hewn

Primed Patterns & Boards



1x6 Primed MDF Nickel Gap



1x6 Primed Clear Fj Radiata Pine Nickel Gap Finesline/#122 (reversible)



1x6 Primed Clear Fj Radiata Pine Car Siding #116/122 (reversible)



1x8 Primed MDF Nickel Gap



1x8 Primed Clear Fj Radiata Pine Nickel Gap Finesline/#122 (reversible)



1x Primed Clear Fj Radiata S4S Eased Edge Boards

1x4x16' 1x4-17' 1x4x16'
1x6x16' 1x12x16'

Cedar Patterns



1x6 Cedar Nickel Gap Finesline (reversible smooth to textured)



1x6 Cedar #122 (reversible smooth to textured)



1 1/16 x 6 Cedar Bevel Siding



1/2x6 Primed Clear Fj Cedar Bevel Siding



1x8 Cedar Nickel Gap Finesline (reversible smooth to textured)



1x8 Cedar Lap & Gap Channel Rustic Siding (reversible to smooth car siding)



1 1/16 x 8 Cedar Bevel Siding



1 5/16 x 10 Cedar Wavy Edge Siding

Other sizes, profiles and species
available special order

Profiles shown not to scale
Call to verify dimensions

Forest Products Supply

(855) 875-7188 / (405) 568-3600

www.fp-supply.com



STAY CONNECTED AND LEARN



www.youtube.com/@forestproductssupply

We post product videos, installation instructions, featured projects, and more on our YouTube channel. We plan to post regular Product Knowledge videos.



www.instagram.com/forest_products_supply/

We post content of our products being used in the field. This is a simple and easy way to see how material is used, learn about products, and see good work. We like to engage the whole supply chain and often repost content from suppliers, contractors, and builders. Sometimes, a picture is worth a thousand words.



We send out marketing emails that highlight specific products. We tend to focus on the peripheral items and these emails are a quick and easy way to learn about what we stock, the features and benefits, general installation guidelines, and FAQ's. We also include a fun trivia question in every email.

ENGINEERED WOOD PRODUCTS



Trus Joist Engineered Wood Products are the #1 rated I-Joist by Builder Magazine, and have been for 15 years running. They are the only brand with a full suite of engineered wood products, including I-Joists, LVL Microllam, PSL Parallam, and LSL Timberstrand.

From performance, to assortment, to quality, Trus Joist is the clear market leader and has the proven performance that builders trust nationwide. Additionally, we have a team of engineers that can help with questions, design, and trouble-shooting from start to finish.

OUR SERVICES

CONSULTING

DESIGN



TJI I-JOISTS



Stock Sizes:

Model	Flange	Lengths	Hangers		L/360 Span @	L/480 Span @
			Top Mount	Face Mount	16" O.C.	16" O.C.
11-7/8" TJI 110	1-3/4"	10'-28'	ITS1.81/11.88	IUS1.81/11.88	19' 4"	18' 5"
11-7/8" TJI 230	2-5/16"	10'-52'	ITS2.37/11.88	IUS2.37/11.88	21' 11"	19' 10"
14" TJI 110	1-3/4"	10'-28'	ITS1.81/14	IUS1.81/14	21'	20' 11"
14" TJI 230	2-5/16"	10'-52'	ITS2.37/14	IUS2.37/14	24' 4"	22' 6"
16" TJI 230	2-5/16"	10'-52'	ITS2.37/16	IUS2.37/16	26'	24' 10"
16" TJI 560	3-1/2"	10'-52'	ITS3.56/16	IUS3.56/16	32' 11"	29' 8"

DESIGN PROPERTIES

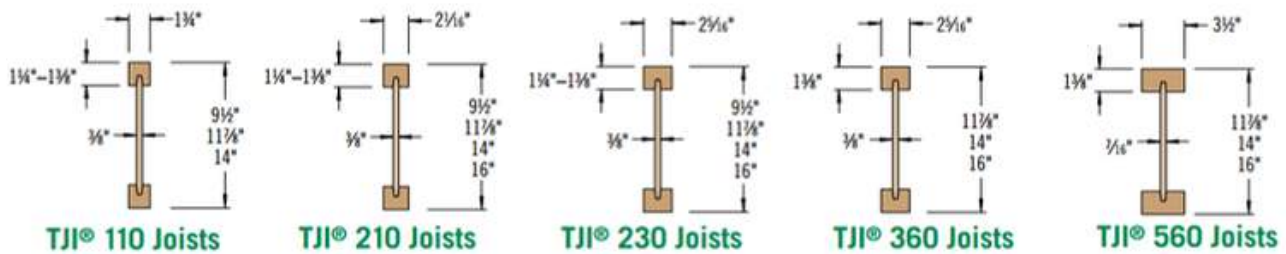

Features & Benefits:

- The #1 rated I-Joist by Builder Magazine for 15 years running
- LVL flange for superior fastening power and squeak-free floor
- Pre-notched holes for easy to run mechanicals
- Multiple depths and flange widths for any conceivable design
- Other series & depths available special order

LVL MICROLLAM



Available Sizes:

Depth	Thickness	Available Lengths	E-Value
9-1/2"	1-3/4"	12' - 52'	2.0 E
11-7/8"	1-3/4"	12' - 52'	2.0 E
14"	1-3/4"	12' - 52'	2.0 E
16"	1-3/4"	12' - 52'	2.0 E
18"	1-3/4"	12' - 48'	2.0 E
20"	1-3/4"	20' - 28'	2.0 E
24"	1-3/4"	12' - 52'	2.0 E

Features & Benefits:

- Waxy watershed overlay finish that beads water and improves long-term storage
- A large mix of depths and lengths for any conceivable application
- Available beam sizing and design by our engineers

TIMBERSTRAND



Headers and Beams:

Width	Depth	Lengths	E-Value
1-3/4"	11-7/8"	12' - 24'	1.55 E
1-3/4"	14"	12' - 24'	1.55 E
3-1/2"	5-1/2"	16'	1.55 E
3-1/2"	11-7/8"	20'	1.55 E
3-1/2"	16"	20'	1.55 E

RimBoard & Concrete Formboard:

Width	Depth	Lengths	Application
1-1/4"	5-1/2"	16'	Form
1-1/4"	7-1/4"	16'	Form
1-1/4"	9-1/2"	16'	Form
1-1/4"	11-7/8"	16'	Form

STURDISTEP® STAIR TREAD



Available Sizes:

Item	Actual Size	Length	Max 2 Stringer Simple Span
<i>SturdiStep</i>	1" x 11-1/2"	16'	45"

Features & Benefits:

- The best performing stair system for quiet, sturdy, and long-lasting stairs
- Engineered wood that is perfectly straight and uniform, and will resist bowing, shrinking, and splitting
- Better nail holding capability that will eliminate squeaky stairs
- Limited product warranty
- Bullnose on one edge, flush on the other

TREATED LSL SILL PLATE



Available Sizes:

Dimension	Actual Size	Available Length	E-Value
2x4	1-1/2" x 3-1/2"	16'	1.3E
2x6	1-1/2" x 5-1/2"	16'	1.3E

Features & Benefits:

- Treated with zinc borate using a proprietary process
- Protects against termites and fungal decay
- Treated throughout—no need for field treatment after cutting or drilling
- Every piece is manufactured to be straight for fast installation
- Limited 25-year product warranty

TIMBERSTRAND FRAMING



Available Sizes:

Dimension	Actual Size	Available Lengths	E-Value
2x4	1-1/2" x 3-1/2"	10, 12, 16, 20, 24	1.3 E
2x6	1-1/2" x 5-1/2"	10, 12, 14, 16, 20, 24, 28	1.3 E
2x8	1-1/2" x 7-1/4"	10, 12, 14, 16, 20, 24, 28	1.5 E

Features & Benefits:

- Perfectly straight - no bowing, twisting or warping
- Strong and stiff (1.3E & 1.5E), making them perfect for tall walls or great rooms with high ceilings
- No sorting or shimming needed
- Helps resist tile, grout, and sheetrock cracks
- Ensures that doors and windows work smoothly and hang straight
- Available in long lengths

RIM BOARD



Available Sizes:

Item	Length	Unit Size
<i>1-1/8" x 11-7/8" TJ® Rim Board</i>	16'	72
<i>1-1/8" x 14" TJ® Rim Board</i>	16'	54
<i>1-1/8" x 16" TJ® Rim Board</i>	16'	54
<i>1-1/4" x 18" Timberstrand® LSL Rim Board</i>	16'	32

Features & Benefits:

- Perfectly uniform, straight, and predictable
- Provides lateral load capacity to protect integrity of structure during high wind shear or seismic events
- Consistent and stable pricing
- Perfectly sized to fit flush with TJI®, LVL's, and PSL's
- 1-1/4" can be used for interior stair stringers

PSL PARALLAMS



Available Sizes:

Size	Available Lengths	E-Value
3-1/2" x 3-1/2"	10', 12', 16'	1.8 E
3-1/2" x 5-1/4"	10', 12', 14', 16', 20', 24'	1.8 E
3-1/2" x 7"	10', 12', 20'	1.8 E
5-1/4" x 5-1/4"	10', 12', 14', 16', 20', 24'	1.8 E
5-1/4" x 7"	10', 12', 20'	1.8 E
7" x 7"	10', 12', 14', 20', 24'	1.8 E

Features & Benefits:

- Perfectly straight - will not bow, twist, or cup
- Available in various lengths and sizes ideal for cantilever and multi-span applications
- No pre-assembly of individual plies. Bolting and nailing are minimized, simplifying installation
- Strong (1.8E) and predictable

SPECIAL ORDER

DOUGLAS FIR GLULAM BEAMS



Available Sizes:

Item	Available Length	Design Value	Grade
<i>3-1/2" x 9-1/2"</i>	<i>12' - 60'</i>	<i>24F-V4 1.8E</i>	<i>Architectural</i>
<i>3-1/2" x 11-7/8"</i>	<i>12' - 60'</i>	<i>24F-V4 1.8E</i>	<i>Architectural</i>
<i>3-1/2" x 14"</i>	<i>12' - 60'</i>	<i>24F-V4 1.8E</i>	<i>Architectural</i>
<i>3-1/2" x 16"</i>	<i>12' - 60'</i>	<i>24F-V4 1.8E</i>	<i>Architectural</i>
<i>5-1/2 x 9-1/2</i>	<i>12' - 60'</i>	<i>24F-V4 1.8E</i>	<i>Architectural</i>
<i>5-1/2" x 11-7/8"</i>	<i>12' - 60'</i>	<i>24F-V4 1.8E</i>	<i>Architectural</i>
<i>5-1/2" x 14"</i>	<i>12' - 60'</i>	<i>24F-V4 1.8E</i>	<i>Architectural</i>
<i>5-1/2" x 16"</i>	<i>12' - 60'</i>	<i>24F-V4 1.8E</i>	<i>Architectural</i>

Features & Benefits:

- Architectural appearance that takes stains exceptionally well.
- Sanded Face and micro-eased edges.
- Knots and voids are filled
- Full 3.5" and 5.5" widths for perfect framing fit.
- Compatible with Common I joist depths.
- 1.9E true stress rating.
- Custom sizes, species and curves available special order

SPECIAL ORDER

DOUGLAS FIR TREATED GLULAM BEAMS



Available Sizes:

Size	Available Lengths	Design Value	Treatment
3-1/2" x 9-1/2"	12' - 48' *	24F-V4 1.8E	HI-CLEAR II Treated
3-1/2" x 11-7/8"	12' - 48' *	24F-V4 1.8E	HI-CLEAR II Treated
3-1/2" x 14"	12' - 48' *	24F-V4 1.8E	HI-CLEAR II Treated
3-1/2" x 16"	12' - 48' *	24F-V4 1.8E	HI-CLEAR II Treated
5-1/2" x 9-1/2"	12' - 48' *	24F-V4 1.8E	HI-CLEAR II Treated
5-1/2" x 11-7/8"	12' - 48' *	24F-V4 1.8E	HI-CLEAR II Treated
5-1/2" x 14"	12' - 48' *	24F-V4 1.8E	HI-CLEAR II Treated
5-1/2" x 16"	12' - 48' *	24F-V4 1.8E	HI-CLEAR II Treated
5-1/2" x 5-1/2"	12' - 48' *	24F-V4 1.8E	HI-CLEAR II Treated

* 4' Increments, certain lengths are unavailable

Features & Benefits:

- Allows for a one piece install that meets code
- Can be stained any color using an oil based stain
- Helps you eliminate posts and columns, opening up lower level patios and yard space
- Easier to work with than steel - cuts, nails, and handles just like regular timber
- HiClear2 Clear treatment for above ground use.
- Custom sizes accessible
- Project pricing available

WOODTONE STRUCTURAL POSTS

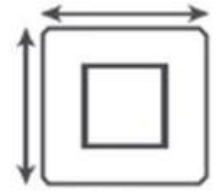

8x8

Actual: 7 1/4" x 7 1/4"

Inside: 4 1/4" x 4 1/4"

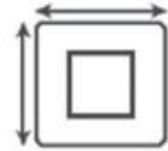

6x6

Actual: 5 1/2" x 5 1/2"

Inside: 2 5/8" x 2 5/8"

Available Sizes:

Item	Actual Dimension	Lengths	Unit Size	Species	Texture	Finish
6 x 6 Primed SPF	5-1/2" x 5-1/2"	10' & 12'	45	SPF	Resawn	Primed
8 x 8 Primed SPF	7-1/4" x 7-1/4"	10' & 12'	28	SPF	Resawn	Primed
6 x 6 Cedar	5-1/2" x 5-1/2"	10' & 12'	45	Cedar	Resawn	Raw Cedar
8 x 8 Cedar	7-1/4" x 7-1/4"	10' & 12'	28	Cedar	Resawn	Raw Cedar

Features & Benefits:

- Engineered to eliminate heavy checking, splits, warp, twist, and bow
- Lightweight and easy to position
- Hollow core allows for electrical to be run through the post
- Available in a primed and paint ready SPF, and a raw Western Red Cedar
- Fully structural with load tables that can be designed into structural support posts

SIMPSON HANGERS

We stock a variety of different EWP-compatible connectors.

Including the four pictured below.

Please call for availability. (405) 568-3600

ITS/MIT Top Mount



IUS Face Mount



SUL/SUR Face Mount



HHUS Face Mount



SIMPSON

Strong-Tie

STUDS



Douglas Fir Studs:

Item	Unit Size	Grade	Species
<i>2x4x92-5/8"</i>	<i>294</i>	<i>#2</i>	<i>Douglas Fir</i>
<i>2x4x104-5/8"</i>	<i>294</i>	<i>#2</i>	<i>Douglas Fir</i>
<i>2x4x116-5/8"</i>	<i>294</i>	<i>#2</i>	<i>Douglas Fir</i>
<i>2x4x128-5/8"</i>	<i>294</i>	<i>#2</i>	<i>Douglas Fir</i>
<i>2x4x140-5/8"</i>	<i>294</i>	<i>#2</i>	<i>Douglas Fir</i>
<i>2x6x92-5/8"</i>	<i>189</i>	<i>#2</i>	<i>Douglas Fir</i>
<i>2x6x104-5/8"</i>	<i>189</i>	<i>#2</i>	<i>Douglas Fir</i>
<i>2x6x116-5/8"</i>	<i>189</i>	<i>#2</i>	<i>Douglas Fir</i>
<i>2x6x128-5/8"</i>	<i>189</i>	<i>#2</i>	<i>Douglas Fir</i>
<i>2x6x140-5/8"</i>	<i>189</i>	<i>#2</i>	<i>Douglas Fir</i>

Interfor HQ (High Quality) Studs:

Item	Length	Unit Size	Grade	Species
<i>2 x 4</i>	<i>92-5/8"</i>	<i>294</i>	<i>#2</i>	<i>Douglas Fir</i>
<i>2 x 4</i>	<i>104-5/8"</i>	<i>294</i>	<i>#2</i>	<i>Douglas Fir</i>
<i>2 x 4</i>	<i>116-5/8"</i>	<i>294</i>	<i>#2</i>	<i>Douglas Fir</i>
<i>2 x 6</i>	<i>92-5/8"</i>	<i>189</i>	<i>#2</i>	<i>Douglas Fir</i>
<i>2 x 6</i>	<i>104-5/8"</i>	<i>189</i>	<i>#2</i>	<i>Douglas Fir</i>
<i>2 x 6</i>	<i>116-5/8"</i>	<i>189</i>	<i>#2</i>	<i>Douglas Fir</i>

DIMENSIONAL LUMBER



Douglas Fir Dimension:

Item	Lengths	Unit Size	Grade	KD/Green
<i>2x4</i>	<i>8' - 20'</i>	<i>294</i>	<i>HQ & #2 Douglas Fir</i>	<i>Kiln Dried</i>
<i>2x6</i>	<i>8' - 20'</i>	<i>189</i>	<i>HQ & #2 Douglas Fir</i>	<i>Kiln Dried</i>
<i>2x8</i>	<i>8' - 20'</i>	<i>96 / 126</i>	<i>#2 Douglas Fir</i>	<i>Kiln Dried</i>
<i>2x10</i>	<i>8' - 20'</i>	<i>80 / 105</i>	<i>#2 Douglas Fir</i>	<i>Kiln Dried</i>
<i>2x12</i>	<i>8' - 20'</i>	<i>64 / 84</i>	<i>#2 Douglas Fir</i>	<i>Kiln Dried</i>

Yellow Pine Dimension:

Item	Length	Unit Size	Grade	Species	Kiln-Dried
<i>2 x 4</i>	<i>8-20'</i>	<i>208</i>	<i>#2</i>	<i>Yellow Pine</i>	<i>Yes</i>
<i>2 x 6</i>	<i>8-20'</i>	<i>128</i>	<i>#2</i>	<i>Yellow Pine</i>	<i>Yes</i>
<i>2 x 8</i>	<i>8-20'</i>	<i>96</i>	<i>#2</i>	<i>Yellow Pine</i>	<i>Yes</i>
<i>2 x 10</i>	<i>8-20'</i>	<i>80</i>	<i>#2</i>	<i>Yellow Pine</i>	<i>Yes</i>
<i>2 x 12</i>	<i>8-20'</i>	<i>64</i>	<i>#2</i>	<i>Yellow Pine</i>	<i>Yes</i>

HEM-FIR FRAMING



Available Sizes:

Nominal Size	Unit Size	Length	Grade	Species
2x6	128	22'-28'	#2&btr	Doug Fir / Hem Fir
2x8	96	22'-28'	#2&btr	Doug Fir / Hem Fir
2x12	64	22'-28'	#2&btr	Doug Fir / Hem Fir
2x6	108	28', 32', 36'	#2&btr	Finger Joint Hem Fir
2x8	84	28', 32', 36'	#2&btr	Finger Joint Hem Fir

Features & Benefits:

- Excellent strength-to-weight ratio
- Available in long lengths up to 28'
- Great for rafters, floor joists, and beams
- Sold in job-pack quantities
- Solid timber, no finger joints

LONG LENGTH DOUGLAS FIR



Available Sizes:

Item	Lengths	Unit Size	Grade	KD/Green
2x6	22' - 28'	189	#2 Douglas Fir	Kiln Dried
2x8	22' - 28'	126	#2 Douglas Fir	Kiln Dried

Features & Benefits:

- Available in long lengths up to 28'
- Available by the individual piece
- Excellent strength-to-weight ratio
- Solid timber, no finger joints
- Great for rafters, floor joists, and beams

MCA TREATED LUMBER



2" Dimensional Pressure Treated:

Item	Grade	Lengths	Treatment	Color	Unit Size
2 x 4	#1 Yellow Pine	8' - 16'	MCA Ground Contact	Green	104
2 x 6	#1 Yellow Pine	8' - 16', 20'	MCA Ground Contact	Green	64
2 x 8	#1 Yellow Pine	8' - 16', 20'	MCA Ground Contact	Green	48
2 x 10	#1 Yellow Pine	12', 16', 20'	MCA Ground Contact	Green	40
2 x 12	#1 Yellow Pine	8' - 16', 20'	MCA Ground Contact	Green	32

- All treated lumber is a #1 MCA Ground Contact
- Available in units, pieces, or job pack quantities

Treated Timbers:

Item	Grade	Lengths	Treatment	Color	Unit Size
4 x 4	#2 Yellow Pine	8', 10', 12' & 16'	MCA Ground Contact	Green	48
4 x 6	#2 Yellow Pine	12' & 16'	MCA Ground Contact	Green	32
6 x 6	#2 Yellow Pine	8', 10', 12' & 16'	MCA Ground Contact	Green	16

- All Timbers are MCA Ground Contact
- Very high quality with four square edges and extremely limited splits
- Available by the unit, in pieces, or job pack quantities

5/4" Premium Radius Edge Decking:

Item	Lengths	Treatment	Treatment Color	Unit Size
5/4 x 6 Premium	8', 10', 12' & 16'	MCA Ground Contact	Green	96

- Radius Edge Decking with a 1/8" eased edge
- Ground Contact treatment for improved longevity
- Premium decking is a very high grade, just shy of a "D"

FIRE TREATED LUMBER



Available Sizes:

Item	Lengths	Grade	Application
<i>2x4</i>	<i>12'&16'</i>	<i>#2</i>	<i>Interior</i>
<i>2x6</i>	<i>12'&16'</i>	<i>#2</i>	<i>Interior</i>
<i>2x8</i>	<i>12'&16'</i>	<i>#2</i>	<i>Interior</i>
<i>2x12</i>	<i>12'&16'</i>	<i>#2</i>	<i>Interior</i>

Features & Benefits:

- Available in both Interior and Exterior fire treated
- Fully pressure impregnated treatment; no surface coatings
- All boards are individually stamped with fire treatment and rating

PREMIUM FURRING STRIPS



Available Sizes:

Item	Actual Size	Unit Size	Species	Sub-Bundled	End Paint
1x2x8	3/4" x 1-1/2"	600	SPF	Yes	Yes
2x2x8	1-1/2" x 1-1/2"	300	SPF	Yes	Yes

Features & Benefits:

- 95% wane free
- S4S (smooth four sides)
- Small tight knots
- Clean bright stock
- Sub-bundled, smaller unit size
- End painted and paper wrapped

DOUGLAS FIR TIMBERS



Available Sizes:

Item	Species	Grade	Lengths	Surface	Green/KD
4 x 4	Douglas Fir	#1 FOHC	8' -12'	Rough Sawn	Green
4 x 6	Douglas Fir	#1 FOHC	8' - 20', 24'	Rough Sawn	Green
4 x 8	Douglas Fir	#1 FOHC	8' - 20', 24'	Rough Sawn	Green
4 x 10	Douglas Fir	#1 FOHC	12', 16', 20', 24'	Rough Sawn	Green
4 x 12	Douglas Fir	#1 FOHC	8' - 20', 24'	Rough Sawn	Green
6 x 6	Douglas Fir	#1 FOHC	8' - 20'	Rough Sawn	Green
6 x 8	Douglas Fir	#1 FOHC	8' - 24'	Rough Sawn	Green
6 x 12	Douglas Fir	#1 FOHC	8' - 24'	Rough Sawn	Green
8 x 8	Douglas Fir	#1 FOHC	8' - 20'	Rough Sawn	Green
8 x 12	Douglas Fir	#1 FOHC	8' - 24'	Rough Sawn	Green
10 x 10	Douglas Fir	#1 FOHC	10', 12'	Rough Sawn	Green
12 x 12	Douglas Fir	#1 FOHC	10', 12'	Rough Sawn	Green

Features & Benefits:

- Premium appearance grade timber that is 100% Free of Heart Center and Free of Wane
- Beautiful auburn coloring and even grain
- #1 Grade for predictable strength bearing and spans
- More affordable than comparable Western Red Cedar sizes

OSB PANELS



We stock a wide range of OSB products to fit any job, including Southern OSB, Radiant Barrier, and T&G.

Available Sizes:

Item	Unit Size	Panel Size
<i>7/16"</i>	<i>78</i>	<i>4' x 8'</i>
<i>7/16" 9 Foot</i>	<i>82</i>	<i>4' x 9'</i>
<i>7/16" 10 Foot</i>	<i>87</i>	<i>4' x 10'</i>
<i>5/8"</i>	<i>54</i>	<i>4' x 8'</i>
<i>3/4"</i>	<i>48</i>	<i>4' x 8'</i>
<i>7/16" Radiant Barrier</i>	<i>78</i>	<i>4' x 8'</i>
<i>5/8" Radiant Barrier</i>	<i>54</i>	<i>4' x 8'</i>
<i>3/4" T&G</i>	<i>48</i>	<i>4' x 8'</i>
<i>3/4" Edge Gold T&G</i>	<i>48</i>	<i>4' x 8'</i>
<i>7/8" Edge Gold T&G</i>	<i>39</i>	<i>4' x 8'</i>
<i>1-1/8" Edge Gold T&G</i>	<i>30</i>	<i>4' x 8'</i>

LP LEGACY® PREMIUM SUB-FLOORING



Available Sizes:

Item	Panel Size	Unit Size	Warranty
3/4"	4 x 8	43	<i>Unlimited Day No Sand</i>
1 1/8"	4 x 8	28	<i>Unlimited Day No Sand</i>

Features & Benefits:

- LP Legacy® Premium Sub-Flooring is a super durable, premium, strand-based composite wood panel designed for demanding sub-floor applications.
- APA-verified to have exceptional stiffness and strength.
- Each wood strand is coated with a water-resistant adhesive that uses Gorilla Glue Technology® for exceptional stiffness and moisture resistance.
- Only LP Legacy sub-flooring offers our Covered Until It's Covered® no-sand warranty—plus a Lifetime Limited Warranty that lasts as long as the home.
- High panel density and superior stiffness provide optimum fastener holding strength for a quieter sub-floor.

LP WEATHERLOGIC®



PANELS

Available Sizes:

Item	Panel Size	Unit Size	Warranty
7/16"	4 x 8	69	30-Year Limited
7/16"	4 x 9	69	30-Year Limited
7/16"	4 x 10	69	30-Year Limited

Features & Benefits:

- Structural I Sheathing
- Can be used for both roof and wall applications for greater versatility
- Available in 4-foot nominal widths and 8-, 9-, or 10-foot lengths
- Seam & Flashing tape is available in 3.75-inch and 6-inch widths; squeegees offer ease of installation and come with every box
- 30-Year Limited Warranty is one of the longest in the industry
- Recognized as carbon negative by ASTM in 2023

EDGE GOLD T&G SUBFLOOR



Available Sizes:

In Stock - Warehouse Items

Item	Panel Size	Unit Size	Warranty	Drainage System
3/4" Edge Gold T&G	4' x 8'	48	50 Year	Yes
7/8" Edge Gold T&G	4' x 8'	39	50 Year	Yes
1-1/8" Edge Gold T&G	4' x 8'	30	50 Year	Yes

Features & Benefits:

- Pound for pound the best bang for your buck in sub-flooring
- 50 Year Warranty and a 200 day no-sand guarantee
- Down Pore Drainage System ensures that water properly drains, protecting against edge swell and sanding before installing hardwood flooring or tile
- Fastener Grid that ships face-up, ready for easy and accurate installation
- Roughly 20% less than the cost of Advantech

YELLOW PINE PLYWOOD



Available Sizes:

Item	Panel Size	Unit Size
<i>3/8" CDX</i>	<i>4' x 8'</i>	<i>90</i>
<i>1/2" CDX</i>	<i>4' x 8'</i>	<i>70</i>
<i>5/8" CDX</i>	<i>4' x 8'</i>	<i>56</i>
<i>3/4" CDX</i>	<i>4' x 8'</i>	<i>48</i>
<i>3/4" T&G Sturd-I-Floor</i>	<i>4' x 8'</i>	<i>48</i>
<i>1-1/8" T&G Sturd-I-Floor</i>	<i>4' x 8'</i>	<i>31</i>
<i>3/4" BB Plyform</i>	<i>4' x 8'</i>	<i>48</i>
<i>1/4" BC</i>	<i>4' x 8'</i>	<i>108</i>
<i>3/8" BC</i>	<i>4' x 8'</i>	<i>108</i>
<i>1/2" BC</i>	<i>4' x 8'</i>	<i>80</i>
<i>5/8" BC</i>	<i>4' x 8'</i>	<i>58</i>
<i>3/4" BC</i>	<i>4' x 8'</i>	<i>48</i>
<i>1/4" AC Radiata</i>	<i>4' x 8'</i>	<i>108</i>
<i>3/8" AC Radiata</i>	<i>4' x 8'</i>	<i>90</i>
<i>1/2" AC Radiata</i>	<i>4' x 8'</i>	<i>72</i>
<i>5/8" AC Radiata</i>	<i>4' x 8'</i>	<i>48</i>
<i>3/4" AC Radiata</i>	<i>4' x 8'</i>	<i>48</i>
<i>5/8" T1-11 - 4" o/c</i>	<i>4' x 8'</i>	<i>58</i>
<i>5/8" T1-11 - 8" o/c</i>	<i>4' x 8'</i>	<i>58</i>
<i>5/8" RB&B - 12" o/c</i>	<i>4' x 8'</i>	<i>58</i>

PINE PLYWOOD SIDING



Available Sizes:

Item	Thickness	Size	Unit Size	Species	Grade
<i>5/8" 4" o.c. T1-11</i>	<i>19/32"</i>	<i>4' x 8'</i>	<i>58</i>	<i>Pine</i>	<i>Premium & Deco</i>
<i>5/8" 8" o.c. T1-11</i>	<i>19/32"</i>	<i>4' x 8'</i>	<i>58</i>	<i>Pine</i>	<i>Premium & Deco</i>
<i>5/8" 12" o.c. RB&B</i>	<i>19/32"</i>	<i>4' x 8'</i>	<i>58</i>	<i>Pine</i>	<i>Premium & Deco</i>

Features & Benefits:

- Easy to install 4'x8' panels with shiplap edges
- Matches siding profiles on older homes for easy replacement
- Premium grade means up to 6 boat patches are allowed per panel. Deco grade allows for up to 18 patches.
- Premium works well for both stain and paint finishes. Deco is primarily intended for paint only finishes.

RADIATA PINE SIDING



Available Sizes:

Item	Actual Thickness	Panel Size	Unit Size	Finish	Grade
<i>3/8" Roughsawn</i>	<i>11/32"</i>	<i>4' x 8'</i>	<i>108</i>	<i>Rough Sawn</i>	<i>Premium</i>
<i>3/8" Beaded</i>	<i>11/32"</i>	<i>4' x 8'</i>	<i>108</i>	<i>2" O.C. Bead</i>	<i>Clear</i>
<i>1/2" T1-11</i>	<i>15/32"</i>	<i>4' x 8'</i>	<i>80</i>	<i>4" O.C. Groove</i>	<i>Premium</i>
<i>1/2" T1-11</i>	<i>15/32"</i>	<i>4' x 8'</i>	<i>80</i>	<i>8" O.C. Groove</i>	<i>Premium</i>

Features & Benefits:

- Premium A-grade face with six patches or less
- More cost-effective than Fir and Yellow Pine
- Radiata Pine is soft, easy to work with, and machines well
- Takes a beautiful coat of stain or paint

PRESSURE TREATED PLYWOOD



Available Sizes:

Item	Actual Thickness	Panel Size	Treatment
1/2"	15/32"	4' x 8'	MCA
3/4"	23/32"	4' x 8'	MCA

Applications:

- Wood foundations
- Retaining walls
- Decks, docks, piers, and floats
- Wet environments like basements and sheds
- Industrial applications, storage, etc.

FIRE TREATED PLYWOOD



Available Sizes:

Item	Actual Thickness	Panel Size	Treatment
<i>1/2" D-Blaze</i>	<i>15/32</i>	<i>4x8</i>	<i>Fire Retardant/Interior</i>
<i>5/8" D-Blaze</i>	<i>19/32</i>	<i>4x8</i>	<i>Fire Retardant/Interior</i>
<i>3/4" D-Blaze</i>	<i>23/32</i>	<i>4x8</i>	<i>Fire Retardant/Interior</i>

Features & Benefits:

- All panels are pressure impregnated, and not top-coated, ensuring permanent protection
- When exposed to fire, non-combustible gas and water vapor are produced, and a layer of protective char forms
- All panels are stamped with their associated fire treatment and certified
- Installs with regular woodworking tools
- Can lower insurance costs

MDF SHELVING



Item	Actual Size	Unit Size
<i>1/4" MDF</i>	<i>1/4" x 49" x 97"</i>	<i>115</i>
<i>3/4" MDF</i>	<i>3/4" x 49" x 97"</i>	<i>55</i>

Features & Benefits:

- Premium MDF panels manufactured to exacting standards
- Commonly used for furniture, cabinets, door parts, store fixtures, toys & musical instruments
- Can be routed, cut, and ripped to size
- Perfectly flat surface that takes paint extremely well

Item	Actual Size	SKU	Unit Size
<i>MDF Square Edge Shelving</i>	<i>11/16" x 12" x 16'</i>	<i>1216M11</i>	<i>96</i>
<i>MDF Square Edge Shelving</i>	<i>11/16" x 16" x 16'</i>	<i>1616M11</i>	<i>72</i>
<i>MDF Bullnose Shelving</i>	<i>11/16" x 12" x 16'</i>	<i>1216M11BN</i>	<i>80</i>
<i>MDF Bullnose Shelving</i>	<i>11/16" x 16" x 16'</i>	<i>1616M11BN</i>	<i>72</i>

Features & Benefits:

- Smooth, grain-free texture
- No sanding required before painting
- Easy to machine and shape

BBOES PLYFORM



Available Sizes:

Item	Thickness	Size	Unit Size	Species
3/4" BBOES Plyform	23/32"	4' x 8'	48	Yellow Pine

Features & Benefits:

Plyform panel with an applied release agent. B-grade face veneer, with B-grade cores and back. Has an oiled edge seal to prevent water absorption. Leaves a smooth uniform finish for concrete, and can be reused up to 5-6 times.

BC YELLOW PINE



Available Sizes:

Item	Thickness	Size	Unit Size	Species
<i>1/4" BC</i>	<i>1/4"</i>	<i>4' x 8'</i>	<i>108</i>	<i>Yellow Pine</i>
<i>3/8" BC</i>	<i>3/8"</i>	<i>4' x 8'</i>	<i>45</i>	<i>Yellow Pine</i>
<i>1/2" BC</i>	<i>15/32"</i>	<i>4' x 8'</i>	<i>36</i>	<i>Yellow Pine</i>
<i>5/8" BC</i>	<i>19/32"</i>	<i>4' x 8'</i>	<i>29</i>	<i>Yellow Pine</i>
<i>3/4" BC</i>	<i>23/32"</i>	<i>4' x 8'</i>	<i>24</i>	<i>Yellow Pine</i>

Features & Benefits:

B-grade sanded veneer face, C-grade cores, and back, exterior glue. BC plywood Pine will have a repaired face that has removed any knots or other defects.

Applications include exterior sheathing, soffits, cabinets, shelving, and paneling.

AC RADIATA PINE



Available Sizes:

Item	Actual Thickness	Panel Size	Unit Size	Finish	Grade
<i>1/4" Radiata Pine</i>	<i>1/4"</i>	<i>4' x 8'</i>	<i>140</i>	<i>Sanded</i>	<i>ACX</i>
<i>3/8" Radiata Pine</i>	<i>11/32"</i>	<i>4' x 8'</i>	<i>108</i>	<i>Sanded</i>	<i>ACX</i>
<i>1/2" Radiata Pine</i>	<i>15/32"</i>	<i>4' x 8'</i>	<i>80</i>	<i>Sanded</i>	<i>ACX</i>
<i>5/8" Radiata Pine</i>	<i>19/32"</i>	<i>4' x 8'</i>	<i>65</i>	<i>Sanded</i>	<i>ACX</i>
<i>3/4" Radiata Pine</i>	<i>23/32"</i>	<i>4' x 8'</i>	<i>54</i>	<i>Sanded</i>	<i>ACX</i>

Features & Benefits:

- Premium A-grade face with six patches or less
- More cost-effective than Fir and Yellow Pine
- Radiata Pine is soft, easy to work with, and machines well
- Takes a beautiful coat of stain or paint
- Can always be used as an underlayment

PARTICLEBOARD



TemStock® Particleboard is an excellent performer in a range of woodworking applications. This family of composite panels provides material solutions for design requirements that include strength, machinability, and surface smoothness, as well as specialty characteristics like fire resistance.

Available Sizes:

Item	Thickness	Size	Description	Unit Size
12PB	1/2"	49" x 97"	Industrial Particleboard	54
58PB	5/8"	49" x 97"	Industrial Particleboard	44
4997PBIS	3/4"	49" x 97"	Industrial Particleboard	34
3412145BS	3/4"	12" x 145"	Particleboard Bullnose Shelving	136
3416145BS	3/4"	16" x 145"	Particleboard Bullnose Shelving	102

Benefits:

- CARB and EPA TSCA Title VI certified

Applications:

- Home and office furniture
- Cabinets and fixtures
- Flooring
- Wall panels

AB MARINE



Available Sizes:

Item	Thickness	Panel Size	Unit Size	Species
<i>1/2" AB Marine</i>	<i>15/32"</i>	<i>4' x 8'</i>	<i>66</i>	<i>Douglas Fir</i>
<i>3/4" AB Marine</i>	<i>23/32"</i>	<i>4' x 8'</i>	<i>44</i>	<i>Douglas Fir</i>

Features & Benefits:

-A-grade veneer face with a B-grade back. Exterior rating and uses an exterior glue that is a water-resistant adhesive. Used for hulls of boats and other applications where a watertight panel is necessary.

HARDWOOD PLYWOOD

Hardwood Plywood is a cabinet or paint grade of plywood that works well for furniture, shelving, cabinets, built-ins, and more. Consumers choose hardwood plywood because it offers a durable and cost-effective alternative to solid wood while also showcasing the natural beauty of wood.

Oak Plywood:

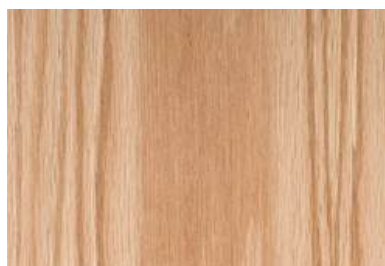

Available Sizes:

Item	Thicknes	Size	Description	Unit Size
14BOB4	1/4"	48" x 96"	B4 Beaded Oak - MDF Core - 1.5" o.c.	60
34OB2VC7	3/4"	48.5" x 96.5"	B2 Oak - WPF - VC	40
34OB2M	3/4"	48" x 96"	B2 Oak - Rotary - MDF Core	40
34WOA1VC	3/4"	48" x 96"	A1 White Oak - PS - VC	40

Birch Plywood:



Available Sizes:

Item	Thicknes	Size	Description	Unit Size
14BC2	1/4"	48" x 96"	C2 Vietnamese Birch - Import	180
12BC2	1/2"	48" x 96"	C2 Vietnamese Birch - Import	78
1255B	1/2"	60" x 60"	B/B Russian Birch (Baltic) - Import	33
34C2CB	3/4"	48" x 96"	C2 Vietnamese Birch - Import	35/50

Maple Plywood:



Available Sizes:

Item	Thicknes	Size	Description	Unit Size
14MB2MDF	1/4"	48" x 96"	B2 Maple - WPF - MDF Core	60
34MB2VC	3/4"	48.5" x 96.5"	B2 Maple - WPF - VC	40
34MC3	3/4"	48.5" x 96.5"	C+3 Cherokee White Maple - VC	40
34MD3VC	3/4"	48" x 96"	D3 Maple - VC	40

Alder Plywood:



Available Sizes:

Item	Thicknes	Size	Description	Unit Size
14BAMDF	1/4"	48" x 96"	Beaded Knotty Alder - MDF Core	60
14AC4MDF	1/4"	48" x 96"	C/C Knotty Alder - PS - MDF Core Domestic	60
34AC4VC	3/4"	48.5" x 96.5"	C/C Knotty Alder - PS - VC	40

DOUGLAS FIR PATTERN



Available Sizes:

Item	Actual Size	Finish	Coverage	Lengths	KD/Green	Grade
1 x 6 Douglas Fir V-Joint	21/32" x 5-3/8"	Smooth/Resawn	2.41 lft/sq ft	12', 16' & 20'	KD	Architect Knotty

Profile:

WP-4/WP-4

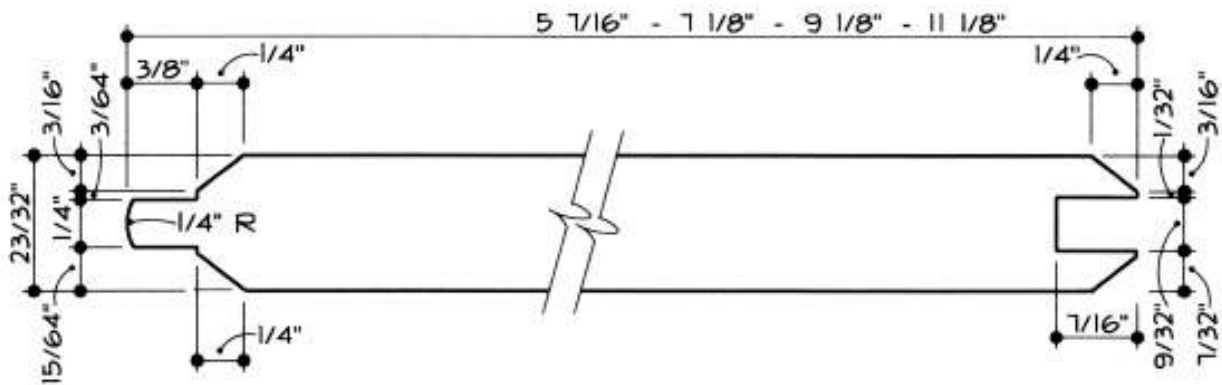

BOARDS

DOUGLAS FIR BOARDS



Available Sizes:

Item	Actual Size	Lengths	Finish	Kiln Dried
<i>1 x 4 Douglas Fir Appearance</i>	<i>7/8" x 3-1/2"</i>	<i>12' & 16'</i>	<i>Rough Face (S1S2E)</i>	<i>Yes</i>
<i>1 x 6 Douglas Fir Appearance</i>	<i>7/8" x 5-1/2"</i>	<i>12' & 16'</i>	<i>Rough Face (S1S2E)</i>	<i>Yes</i>
<i>1 x 8 Douglas Fir Appearance</i>	<i>7/8" x 7-1/4"</i>	<i>12' & 16'</i>	<i>Rough Face (S1S2E)</i>	<i>Yes</i>
<i>1 x 12 Douglas Fir Appearance</i>	<i>7/8" x 11-1/4"</i>	<i>12', 16', 20'</i>	<i>Rough Face (S1S2E)</i>	<i>Yes</i>

Features & Benefits:

- Tight knot appearance grade board
- Kiln Dried (12-15% moisture content)
- Rougher-headed face (smooth backside and two edges)
- Excellent price when compared to Cedar
- Full 7/8" thick
- Beautiful color, texture, and grain

CANFOR WYNNWOOD PREMIER BOARDS



BOARDS

Available Sizes:

Item	Length	Unit Size	Grade	Finish	Species
1 x 4	8' - 16'	280	#2 Premier	S4S Eased Edge	ESLP
1 x 6	8' - 16'	180	#2 Premier	S4S Eased Edge	ESLP
1 x 8	8' - 16'	140	#2 Premier	S4S Eased Edge	ESLP
1 x 10	8' - 12'	100	#2 Premier	S4S Eased Edge	ESLP
1 x 12	8' - 16'	80	#2 Premier	S4S Eased Edge	ESLP

Features & Benefits:

- The highest quality finish of any board in North America
- Engelmann Spruce and Lodgepole Pine mix
- Supersedes NLGA or WWPA grades with 50% less wane, almost no blue and strict limits on end splits.
- Beautiful straw like color and uniform grain that takes paint and stain exceptionally well
- Micro-eased 1/16th-inch radius edge
- All boards are end waxed and stamped KDHT
- Milled in one of the most sustainable and consistent fiber baskets in North America

WYNNWOOD INDUSTRIAL BOARDS



Available Sizes:

Item	SKU	Length	Unit Size	Grade	HT Stamp
1 x 4	1412WP4	12'	588	Industrial	Yes
1 x 4	1416WP4	16'	588	Industrial	Yes

Features & Benefits:

- A mill downfall grade that contains a good mix of #3 and even #2 grade boards
- 1x4 is an excellent solution for crating, roof purlins, and concrete forming
- Excellent price and value compared to #3 boards
- A mix of Engelmann Spruce, Lodgepole Pine, Hemlock, and Fir
- All boards are HT stamped



PINE CARSIDING



Profile:

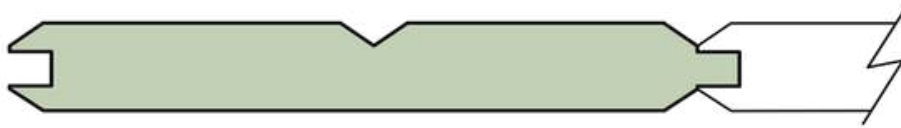

1x6 White Pine Premier #116 / #122 (reversible) | Coverage: 240 LFT/SQ

1x6 White Pine Classic #116 / #122 (reversible) | Coverage: 240 LFT/SQ

1x6 #2 Yellow Pine #116 / #122 (reversible) | Coverage: 240 LFT/SQ



1x8 White Pine Premier #116 / #122 (reversible) | Coverage: 180 LFT/SQ

1x8 White Pine Classic #116 / #122 (reversible) | Coverage: 180 LFT/SQ

**profiles are not to scale*

Features & Benefits:

- T&G for easy install
- Reversible - WP4/Pattern 116
- Versatile - can be painted, stained, or whitewashed
- More dimensionally stable and easier to paint than Yellow Pine
- Available in multiple lengths
- Multiple applications: interior paneling, porch ceilings, wainscoting, etc.

PINE FINELINE (T&G SHIPLAP)



Profile:



1x6 White Pine Premier Fineline / #122 (reversible) | Coverage: 240 LFT/SQ

1x6 White Pine Classic Fineline / #122 (reversible) | Coverage: 240 LFT/SQ



1x8 White Pine Premier Fineline / #122 (reversible) | Coverage: 180 LFT/SQ

1x8 White Pine Classic Fineline / #122 (reversible) | Coverage: 180 LFT/SQ

**profiles are not to scale*

Features & Benefits:

- Leaves a perfect 1/8" Nickel Gap
- T&G for easy install
- Reversible - Nickel Gap/V-Groove
- Versatile - can be painted, stained, or whitewashed
- More dimensionally stable and easier to paint than Yellow Pine
- Available in multiple lengths

PINE EDGE & CENTER BEAD



Profile:

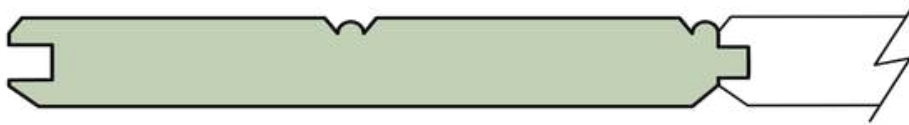

1x4 White Pine Premier Edge & Center Bead / #122 (reversible) | Coverage: 400 LFT/SQ

1x6 White Pine Premier Edge & Center Bead / #122 (reversible) | Coverage: 240 LFT/SQ

1x6 White Pine Classic Edge & Center Bead / #122 (reversible) | Coverage: 240 LFT/SQ

**profiles are not to scale*

PINE DROP SIDING



1x6 #2 Yellow Pine #105 Drop Siding | Coverage: 240 LFT/SQ

1x8 #2 Yellow Pine #105 Drop Siding | Coverage: 180 LFT/SQ

**profiles are not to scale*

PINE NOVELTY SIDING



Profile:

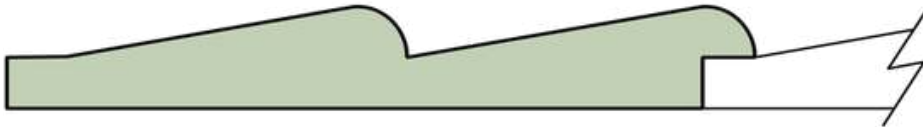

1x6 #2 Yellow Pine #117 Novelty Siding | Coverage: 240 LFT/SQ

**profiles are not to scale*

PINE SHIPLAP SIDING



1x8 #2 Yellow Pine Shiplap Siding | Coverage: 180 LFT/SQ

**profiles are not to scale*

PINE BOSTON SIDING



Profile:



1x8 #2 Yellow Pine #131 Boston Siding | Coverage: 180 LFT/SQ

**profiles are not to scale*

BOARDS

PINE LOG CABIN SIDING

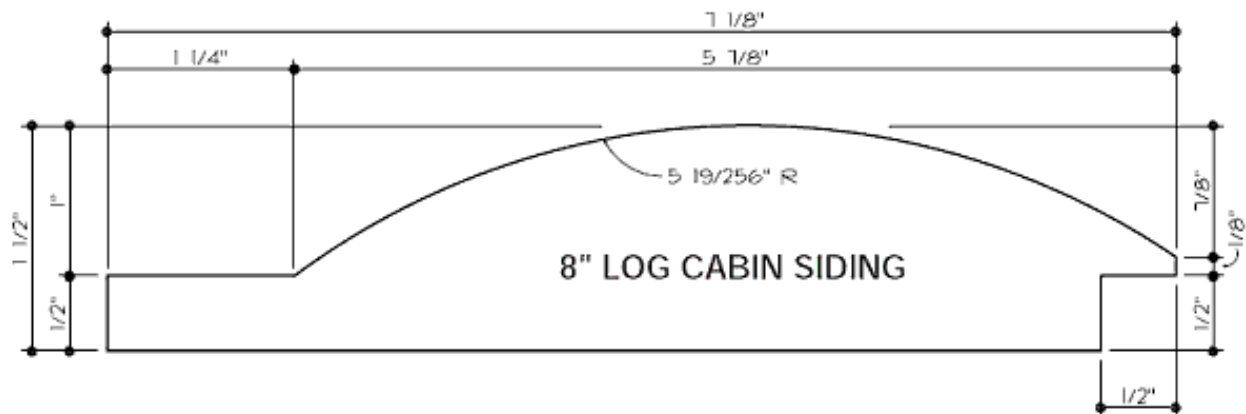

2x8 Smooth Round Log Cabin Siding | Coverage: 180 LFT/SQ

**profiles are not to scale*

PINE LOG CABIN SIDING

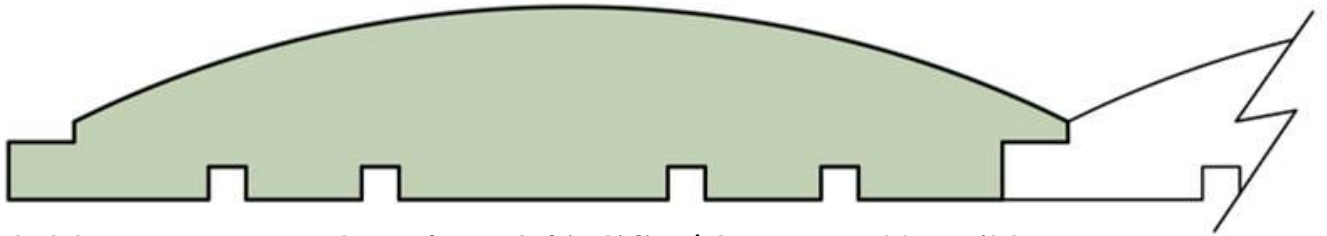

2x8 Spruce Log-to-Log Smooth Log Cabin Siding | Coverage: 180 LFT/SQ

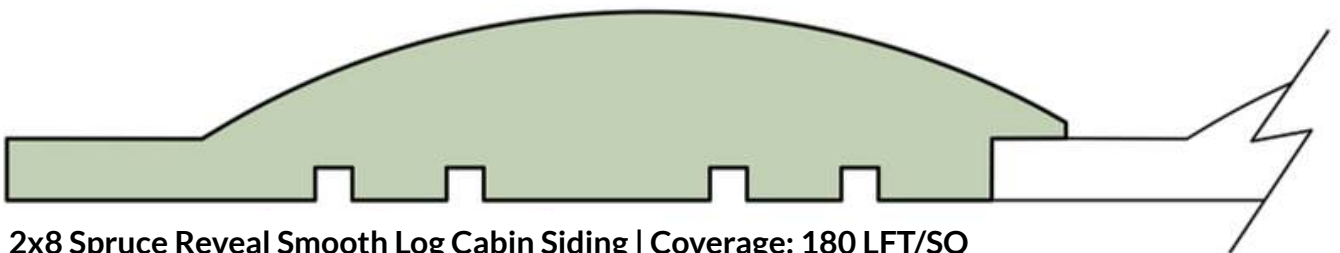

2x8 Spruce Reveal Smooth Log Cabin Siding | Coverage: 180 LFT/SQ

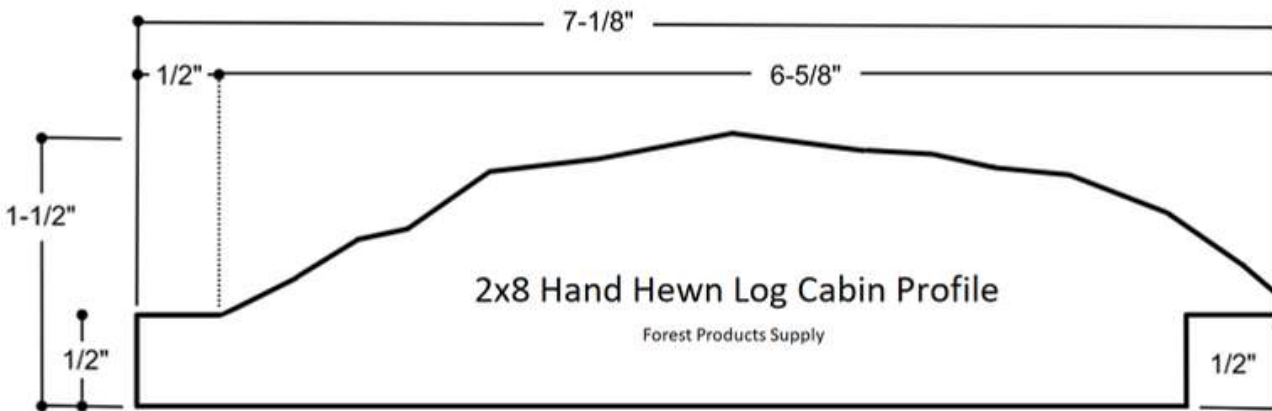

2x8 Spruce Log-to-Log Hand Hewn Log Cabin Siding | Coverage: 180 LFT/SQ

**profiles are not to scale*

2X6 PINE V-JOINT T&G DECKING



BOARDS

Available Sizes:

Item	Available Lengths	Species	Profile
2x6 Roof Decking	12' & 16'	Lodgepole / Pon Pine Mix	T&G V-Groove

Features & Benefits:

- Beautiful color, grain, and knot structure
- Great for roof decking, loft floors, and porch ceilings
- All knots sound and tight
- T&G V-Groove face / flush back
- KDHT
- Added insulation value (1.9R)
- WWPA Select Deck Stamp



Profile:

Face Coverage = 4-7/8"

240 LFT/SQ

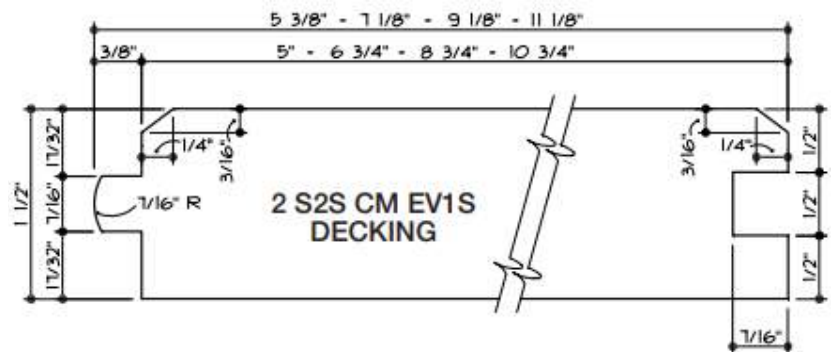

PRIMED PINE BOARDS & PATTERNS



Available Trim Sizes:

Item	SKU	Actual Size	Length	Unit Size	Species	Grade	Finish
1x4 S4S	1416PRPFJ	0.75" x 3.5"	16' & 17'	204	Radiata Pine	Clear FJ	Double Primed
1x6 S4S	1616PRPFJ	0.75" x 5.5"	16'	136	Radiata Pine	Clear FJ	Double Primed
1x8 S4S	1816PRPFJ	0.75" x 7.25"	16'	102	Radiata Pine	Clear FJ	Double Primed
1x12 S4S	11216PRPFJ	0.75" x 11.25"	16'	54	Radiata Pine	Clear FJ	Double Primed

Features & Benefits:

- Imported Chilean Radiata Pine
- X-Ray scanned for clear blocks, inside and outside
- Primed boards feature oil based first coat and acrylic latex second coat
- One year warranty on primer, 10 year on substrate glue

Primed Pine Pattern:



1x6 Primed FJ Radiata Pine Finline / #122 (reversible) | Coverage: 240 LFT/SQ

**profiles are not to scale*



1x8 Primed FJ Radiata Pine Finline / #122 (reversible) | Coverage: 180 LFT/SQ

**profiles are not to scale*

PRIMED MDF NICKEL GAP

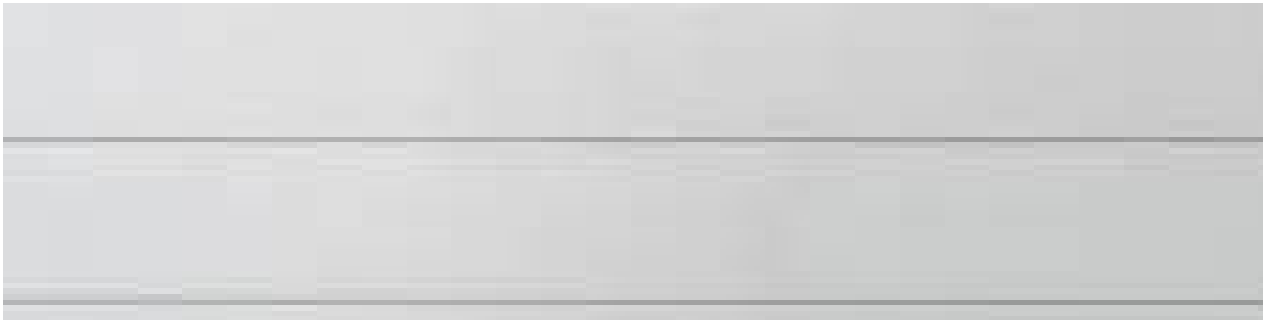

Profile:



1x6 Primed MDF Nickel Gap | Coverage: 240 LFT/SQ



1x8 Primed MDF Nickel Gap | Coverage: 170 LFT/SQ

**profiles are not to scale*

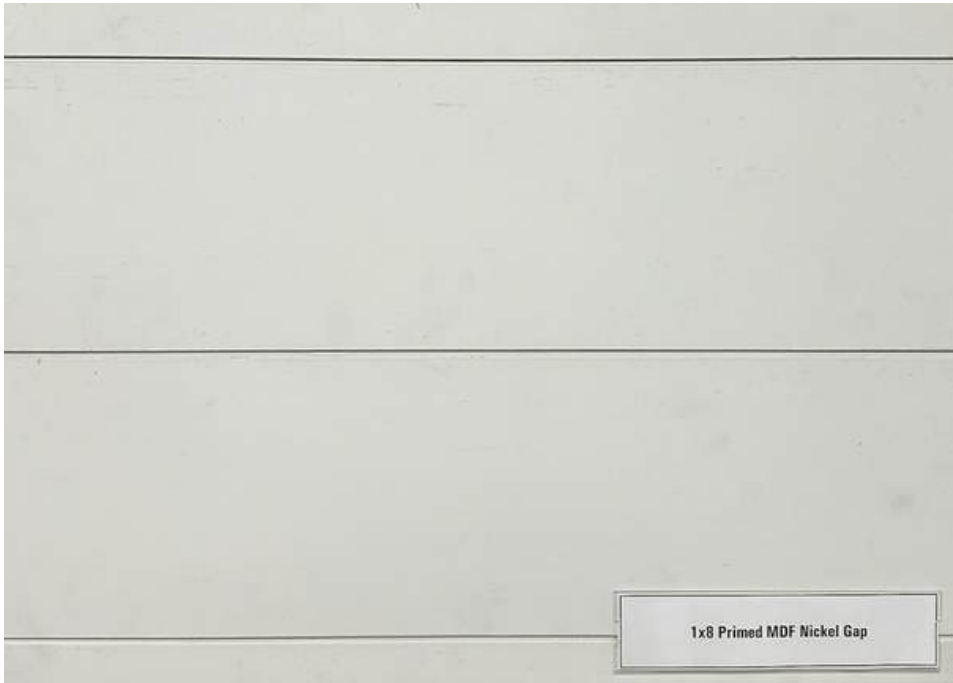

BOARDS

C&BTR S4S RADIATA PINE



Available Sizes:

Item	Actual Size	Lengths	Unit Size	Grade	Finish
<i>1 x 4 Clear Pine</i>	<i>0.75" x 3.5"</i>	<i>16'</i>	<i>240</i>	<i>C&btr</i>	<i>Radiata Pine</i>
<i>1 x 6 Clear Pine</i>	<i>0.75" x 5.5"</i>	<i>16'</i>	<i>140</i>	<i>C&btr</i>	<i>Radiata Pine</i>
<i>1 x 8 Clear Pine</i>	<i>0.75" x 7.25"</i>	<i>16'</i>	<i>100</i>	<i>C&btr</i>	<i>Radiata Pine</i>
<i>1 x 12 Clear Pine</i>	<i>0.75" x 11.25"</i>	<i>16'</i>	<i>80</i>	<i>C&btr</i>	<i>Radiata Pine</i>

Features & Benefits:

- Imported from New Zealand and cut from some of the finest Radiata Pine in the world
- Clear stain or paint grade
- Square edge corners
- Sold by the piece

WESTERN RED CEDAR



Cedar is in our DNA, and we focus only on sourcing high-quality material from the best manufacturers in the world.

Factors we look for are:

Fiber Quality – We stock premium coastal Western Red Cedar

Color – The darker and richer, the better

Texture & Grain – We want to showcase the natural beauty of Cedar

Assortment – We have the deepest inventory of on-ground Cedar

OUR PROUD PARTNER:

WESTERN

Forest Products

CEDAR DECKING



Available Sizes:

Item	Finish	Actual Size	Lengths	Species	Grade
5/4x6	Smooth	1" x 5-9/16"	8' - 16'	Western Red Cedar	Architectural Knotty
2x6	Smooth	1-9/16" x 5-9/16"	8' - 16'	Western Red Cedar	Architectural Knotty

Features & Benefits:

- True Western Red Cedar milled in British Columbia
- Architectural Knotty grade
- Beautiful rich auburn color with tight uniform grain
- Stays cool on your feet in the hot summer sun
- 100% Sustainable, and SFI Certified
- Contains natural oils and resins that make it resistant to rot, decay, and insects
- All knots are sound and tight, maximum knot size = 2 7/8" and wane is strictly limited to the reverse face only

CEDAR APPEARANCE GRADE BOARDS



Available Sizes:

Item	Actual Size	Lengths	Finish	Grade
1x2	3/4" x 1-1/2"	8' - 16'	Smooth/Rough	Appearance
1x4	3/4" x 3-9/16"	8' - 20'	Smooth/Rough	Appearance
1x6	3/4" x 5-9/16"	8' - 20'	Smooth/Rough	Appearance
1x8	3/4" x 7-3/8"	8' - 20'	Smooth/Rough	Appearance
1x10	3/4" x 9-3/8"	8', 12', 16'	Smooth/Rough	Appearance
1x12	3/4" x 11-3/8"	8' - 20'	Smooth/Rough	Appearance

Features & Benefits:

- True Western Red Cedar milled in British Columbia
- Appearance Grade
 - No-hole knotty boards
 - Straight, uniform grain and even texture
- "No Prior Select" meaning that grades are not pulled out during production
- S1S2E (smooth one side, two edges)
- Contains natural oils and resins that make it resistant to decay and insects
- Available up to 20' in length
- SFI certified and 100% sustainable

CEDAR

CEDAR DIMENSIONAL



Available Sizes:

Item	Surface	Actual Size	Length	Species	KD/Green
2x2	Rough	1-3/4" x 1-3/4"	8' - 16'	Western Red Cedar	Green
2x4	Rough	1-3/4" x 3-3/4"	8' - 20'	Western Red Cedar	Green
2x6	Rough	1-3/4" x 5-3/4"	8' - 20'	Western Red Cedar	Green
2x8	Rough	1-3/4" x 7-3/4"	8' - 20'	Western Red Cedar	Green
2x10	Rough	1-3/4" x 9-3/4"	8' - 20'	Western Red Cedar	Green
2x12	Rough	1-3/4" x 11-3/4"	8' - 20'	Western Red Cedar	Green
2x6	Smooth	1-9/16" x 5-9/16"	8' - 16'	Western Red Cedar	Green

Features & Benefits:

- True Western Red Cedar, milled in British Columbia
- Contains natural oils and resins that make it resistant to insects, rot, and decay
- All Cedar is a no hole knotty appearance grade with extremely limited wane
- Rough cedar is a full rough cut and run through a rougher header for a high-quality appearance
- 100% Sustainable Forest Initiative Certified

CEDAR TIMBERS



Available Sizes:

Item	Lengths	Grade	KD/Green
4 x 4 Rough	8' - 16'	Appearance Grade	Green
4 x 6 Rough	8' - 20'	Appearance Grade	Green
4 x 8 Rough	8' - 20'	Appearance Grade	Green
4 x 12 Rough	8' - 26'	Appearance Grade	Green
6 x 6 Rough	8' - 20'	Appearance Grade	Green
6 x 8 Rough	8' - 20'	Appearance Grade	Green
6 x 12 Rough	8' - 20', 24'	Appearance Grade	Green
8 x 8 Rough	8' - 20'	Appearance Grade	Green
8 x 12 Rough	8' - 20'	Appearance Grade	Green
10 x 10 Rough	10', 12'	Appearance Grade	Green
12 x 12 Rough	8', 10', 12'	Appearance Grade	Green

Features & Benefits:

- Premium coastal Western Red Cedar milled in British Columbia
- Beautiful rich auburn coloring and tight uniform grain
- Appearance grade no hole knotty cedar with four square edges
- Great for both interior appearance applications and exterior structural posts/beams
- Contains natural oils and resins that make it resistant to insects, rot, and decay
- 100% sustainable and SFI certified

CEDAR BEVEL SIDING



Available Sizes:

Item	Exposure	Coverage	Lengths	KD/Green	Grade
<i>1 1/16" x 6" Knotty</i>	<i>4"</i>	<i>300 LF/SQ</i>	<i>8' - 16'</i>	<i>KD</i>	<i>Architect Knotty</i>
<i>1 1/16" x 8" Knotty</i>	<i>6"</i>	<i>200 LF/SQ</i>	<i>8' - 16'</i>	<i>KD</i>	<i>Architect Knotty</i>

Features & Benefits:

- True Western Red Cedar, milled in British Columbia
- Contains natural oils and resins that make it resistant to rot, decay, and insects
- Excellent for siding and available in multiple profiles
- Lightweight, and easy to work with
- Available in a Clear Vertical Grain and a no hole Architectural Knotty grade

Applications: Exterior siding

CEDAR V-JOINT SIDING



Available Sizes:

Item	Actual Size	Finish	Coverage	Lengths	KD/Green	Grade
1x6 V-Joint	1 1/16" x 5-3/8"	Smooth/Rough	240 LF/SQ	8' - 20'	KD	Architect Knotty

*Reversible

CEDAR

CEDAR LAP & GAP (CHANNEL RUSTIC) SIDING



Available Sizes:

Item	Exposure	Finish	Coverage	Lengths	KD/Green	Grade
1x8 Channel	6-1/4"	Rough	195 LF/SQ	8' - 20'	KD	Architect Knotty

CEDAR FINELINE NICKEL GAP

Rough Face



Smooth Face

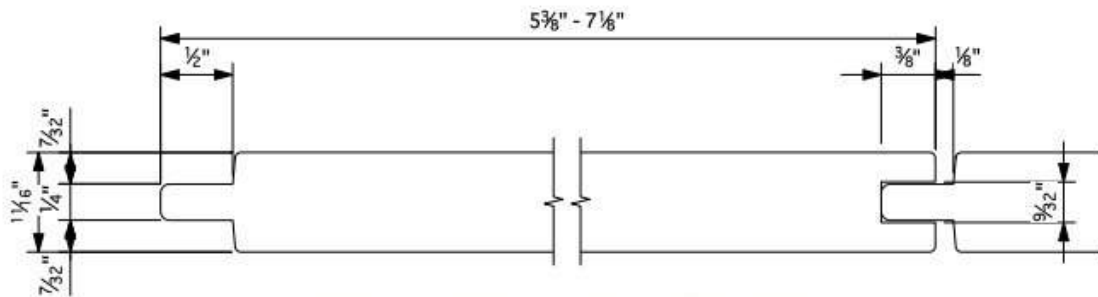

Elite Fineline (1/8th Gap) Paneling

Available Sizes:

Item	Lengths	Exposure	Coverage	Finish	Species
1x6 Fineline	8' - 16'	5"	240 LF/SQ	Smooth/Rough	Western Red Cedar
1x8 Fineline	8' - 16'	6-3/4"	180 LF/SQ	Smooth/Rough	Western Red Cedar

Features & Benefits:

- True Western Red Cedar, milled in British Columbia
- Contains natural resins and oils that make it resistant to insects, rot, and decay
- Popular 1/8" Nickel Gap
- Reversible: smooth and rough
- Kiln Dried for superior dimensional stability
- Excellent for exterior siding, porch ceilings, soffit, and accent walls
- SFI certified and 100% sustainable material

WAVY EDGE CEDAR SIDING



Available Sizes:

Item	Actual Thickness	Actual Width	Lengths	Exposure	Coverage
<i>Wavy Edge Siding</i>	<i>15/16"</i>	<i>9-1/8" - 8-1/2"</i>	<i>8' - 16' Evens</i>	<i>7.5"</i>	<i>160 LF/SQ</i>

Features & Benefits:

- 100% Western Red Cedar
- Excellent for siding, gables, and accents
- Tight-knot appearance grade
- Lightweight and easy to install
- Authentic rustic look with natural wavy variation
- Thermally efficient and very durable
- Contains natural oils and resins that make it resistant to insects, rot, and decay

CEDAR DOG EAR FENCING



Available Sizes:

Item	SKU	Actual Size	Finish	Unit Size	Species
<i>5/8" x 4" Dog Ear</i>	<i>5846CDJ</i>	<i>5/8" x 3-1/2" x 6'</i>	<i>Rough/Rough</i>	<i>Varies</i>	<i>Japanese Sugi</i>
<i>5/8" x 6" Dog Ear</i>	<i>5866CDJ</i>	<i>5/8" x 5-1/2" x 6'</i>	<i>Rough/Rough</i>	<i>Varies</i>	<i>Japanese Sugi</i>
<i>7/8" x 4" Dog Ear</i>	<i>146CDJ</i>	<i>7/8" x 3-1/2" x 6'</i>	<i>Rough/Rough</i>	<i>Varies</i>	<i>Japanese Sugi</i>
<i>7/8" x 6" Dog Ear</i>	<i>166CDJ</i>	<i>7/8" x 5-1/2" x 6'</i>	<i>Rough/Rough</i>	<i>Varies</i>	<i>Japanese Sugi</i>
<i>7/8" x 6" Dog Ear</i>	<i>168CDJ</i>	<i>7/8" x 5-1/2" x 8'</i>	<i>Rough/Rough</i>	<i>Varies</i>	<i>Japanese Sugi</i>
Fence Rails	Surface	Lengths	Species	Green	
<i>2x4 Std & Btr</i>	<i>S4S</i>	<i>8', 10', 12' & 16'</i>	<i>Western Red Cedar</i>	<i>Yes</i>	

Features & Benefits:

- Contains natural oils and resins that make it resistant to rot and decay
- Dog Eared Trimmed
- Full 7/8" thick fencing is extremely durable and stout - excellent for backyards with kids and kicked soccer balls and toys
- Full and broken units available

CEDAR SHAKES



CEDAR

Available Sizes:

Item	Length	Thickness	Exposure	Grade	Coverage
<i>Medium Shakes</i>	24"	1/2" - 3/4"	10"	#1 80% Edge Grain	20 Sq Ft/Bundle

Features & Benefits:

- Naturally beautiful and adds tremendous curb appeal
- Extremely durable & of the absolute highest quality
- 100% sustainable & natural
- Significantly more environmentally friendly than asphalt shingles
- Random widths for natural variety



**Medium Shake
1/2" - 3/4" Thick**

CEDAR SHINGLES



Available Sizes:

Item	Length	Grade	Roof		Wall	
			Exposure	Coverage	Exposure	Coverage
16" Fivex	16"	#1 Blue Label 100% Edge Grain	5"	25 Sq Ft	7"	33 Sq Ft

Features & Benefits:

- Delivers a classic Cape Cod look
- Extremely durable & of the absolute highest quality
- Adds tremendous curb appeal
- 100% sustainable & natural
- Significantly more environmentally friendly than asphalt shingles
- Various exposures available
- Random widths for natural variety



**16" #1 "Fivex"
Shingles**

FIR 2X6 T&G ROOF DECKING



Available Sizes:

Item	Lengths	Profile	Exposure	Coverage	Species	Grade
2x6 T&G Fir	12' & 16'	T&G WP4	4-7/8"	246 LF/SQ	Fir & Larch	Select

Features & Benefits:

- Great for roof decking, loft floors, and outdoor patios
- Face coverage = 4-7/8", so factor 246 LF per square
- Premium Select grade for appearance and strength
- Beautiful color, grain, and knot structure
- Brings an added insulation value (1.9R)
- Available in multiple lengths
- Simple span of 6'-8' is easily achievable, but always check with local designs and load factors
- Priced comparably to other common roof decking species (Yellow Pine, SPF, etc)

DECKORATORS DECKING

We offer four lines of Deckorators Decking, each offering unique benefits for your clients. Deckorators products are as strong and highly functional as they are attractive. Each is smartly engineered, made of top-quality materials, and durably coated for greater protection against the elements, assuring year after year of lasting beauty with minimal care.

VENTURE LINE - \$

- A low cost, value oriented wood-plastic composite deck line.
- Scalloped back, available in two colors, and sold at an amazing price.
- Venture is a great product for those looking for the lowest cost option to replace wood while still keeping minimal maintenance.

Available Colors:

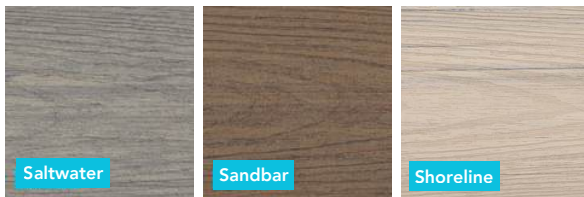

Available Profiles:

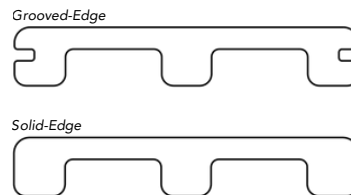

VISTA LINE - \$\$

- A well-rounded and top-performing wood-plastic capped composite deck line.
- Built with enhanced traction.
- Full 7/8" board, available in four colors, and sold at an average price point.
- Vista is a great product for those looking for solid all-around performance and longevity, but want to stay within a specific budget.

Available Colors:



Available Profiles:

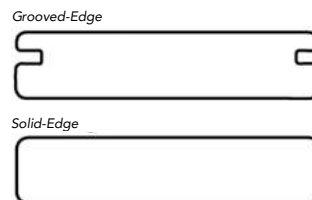

DECKORATORS DECKING

We offer four lines of Deckorators Decking, each offering unique benefits for your clients. Deckorators products are as strong and highly functional as they are attractive. Each is smartly engineered, made of top-quality materials, and durably coated for greater protection against the elements, assuring year after year of lasting beauty with minimal care.

SUMMIT LINE - \$\$

- Mineral-based composite technology, which offers the industry's best strength-to-weight ratio
- 35% lighter than other traditional composite deck boards
- Unique surface that improves traction in wet conditions
- Won't splinter, sag, chalk, or crack
- 11¼" fascia available in 12' length only

Available Colors:

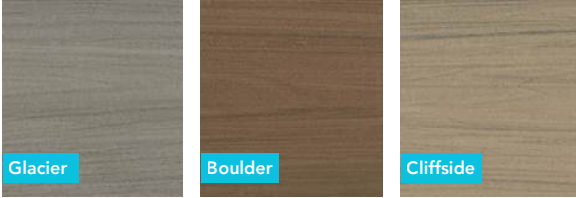



Glacier Boulder Cliffside

Available Profiles:

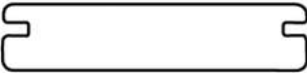
Grooved-Edge



Solid-Edge

VOYAGE LINE - \$\$\$

- A lightweight mineral-based composite with incredible durability and extremely limited movement. Built with enhanced traction.
- The best overall performing composite deck on the market.
- Full 7/8" board, available in six colors, narrow and wide boards available, and sold at a premium price level that suits the quality.
- Voyage is the right product for those looking for the best overall performance in composite decking and want their deck to look as good in year 10 as year 1.

Available Colors:





Sedona Sierra Tundra Costa Mesa Khaya

Available Profiles:

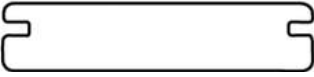
Grooved-Edge



Solid-Edge

DECKING

DECKORATORS DECKING - VENTURE

A wood-plastic composite deck board that offers the best combination of value and performance. Venture Decking features a natural woodgrain in three colors Saltwater (gray), Sandbar (brown), and Shoreline (tan).

Available Sizes:

Line	Type	Item	Actual Size	Unit Size
Venture	Grooved Deck Board	5/4 x 6 x 12' Grooved	15/16" x 5-1/2" x 12'	48
Venture	Grooved Deck Board	5/4 x 6 x 16' Grooved	15/16" x 5-1/2" x 16'	48
Venture	Grooved Deck Board	5/4 x 6 x 20' Grooved	15/16" x 5-1/2" x 20'	48
Venture	Solid Deck Board	5/4 x 6 x 16' Solid	15/16" x 5-1/2" x 16'	48
Venture	Solid Deck Board	5/4 x 6 x 20' Solid	15/16" x 5-1/2" x 20'	48
Venture	Fascia	1 x 12 x 12' Fascia	1/2" x 11-1/4" x 12'	40



Available Colors:

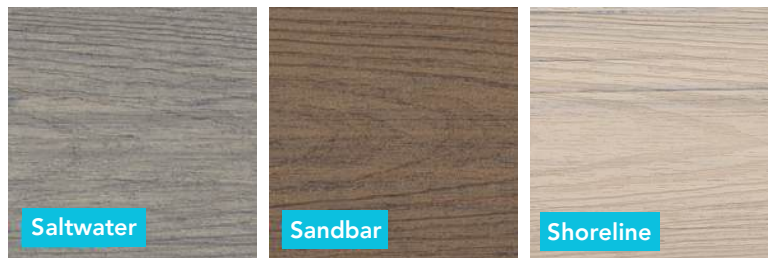

Available Profiles:

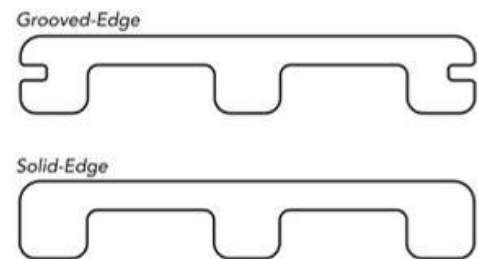

Features & Benefits:

- Scratch-resistant polyethylene cap with a strong, dense composite core
- Capped on three sides and through the groove
- Fluted backside; lightweight and easy to maneuver and position
- Easy to clean with soap and water, and resistant to rot, mold, and scratches
- Spans 16" on-center
- Backed by a 25-year limited warranty: 25-year Structural, 25-year Stain & Fade, and 25-year Limited Removal & Replacement Warranty

DECKORATORS DECKING - VISTA

A wood-plastic composite deck board with the look of exotic hardwoods without the maintenance. Deckorators Vista Line comes in four different colors Driftwood, Silverwood, Ironwood, and Dunewood.

Available Sizes:

Line	Type	Item	Actual Size	Unit Size
Vista	Grooved Deck Board	5/4 x 6 x 12' Grooved	7/8" x 5-1/2" x 12'	48
Vista	Grooved Deck Board	5/4 x 6 x 16' Grooved	7/8" x 5-1/2" x 16'	48
Vista	Grooved Deck Board	5/4 x 6 x 20' Grooved	7/8" x 5-1/2" x 20'	48
Vista	Solid Deck Board	5/4 x 6 x 16' Solid	7/8" x 5-1/2" x 16'	48
Vista	Solid Deck Board	5/4 x 6 x 20' Solid	7/8" x 5-1/2" x 20'	48
Vista	Fascia	1 x 12 x 12' Fascia	1/2" x 11-1/4" x 12'	40

Available Colors:



Available Profiles:



Features & Benefits:

- 12', 16', and 20' lengths available in solid- and grooved-edge profiles
- Scratch-resistant cap with a strong, dense composite core
- Industry-leading warranty: 25-year Structural, 25-year Stain & Fade, and 25-year Removal & Replacement
- 8" and 11¼" fascia available in 12' length

DECKORATORS DECKING - VOYAGE

A mineral-based composite technology line, which provides the industry's best strength-to-weight ratio. Featuring a fiber-like structure similar to wood, Voyage has unmatched strength that is nearly 35% lighter than traditional composites and similar in weight to PVC.

Available Sizes:

Line	Type	Item	Actual Size	Unit Size
Voyage	Grooved Deck Board	5/4 x 6 x 12' Grooved	7/8" x 5-1/2" x 12'	48
Voyage	Grooved Deck Board	5/4 x 6 x 16' Grooved	7/8" x 5-1/2" x 16'	48
Voyage	Grooved Deck Board	5/4 x 6 x 20' Grooved	7/8" x 5-1/2" x 20'	48
Voyage	Solid Deck Board	5/4 x 6 x 16' Solid	7/8" x 5-1/2" x 16'	48
Voyage	Solid Deck Board	5/4 x 6 x 20' Solid	7/8" x 5-1/2" x 20'	48
Voyage	Fascia	1 x 12 x 12' Fascia	7/16" x 11-1/4" x 12'	40
Voyage	Dark Slate Accent Board	5/4 x 6 x 21' Solid	7/8" x 5-1/2" x 21'	48
Voyage	Dark Slate Accent Fascia	1 x 12 x 12' Fascia	7/16" x 11-1/4" x 12'	40

Available Colors:



Available Profiles:

Grooved-Edge

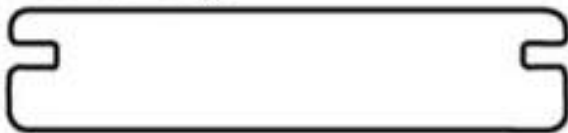

Solid-Edge



Features & Benefits:

- Mineral Based Composite technology
- Virtually zero thermal expansion and contraction
- Incredible strength and durability; virtually impossible to crack and break
- Lightweight easy to work with and install; 35% lighter than traditional wood plastic composites
- Approved for ground contact and water installation
- Won't splinter, sag, chalk, or crack
- Stain and fade-resistant cap stock
- Can be used as residential and commercial cladding

DECKORATORS FASTENERS

VENTURE LINE FASTENERS

Item	SKU	Hidden Fasteners	
		Size	Coverage
Camo Stealthlock	CSL500	90 COUNT	50 SQ FT
Camo Stealthlock	CSL250	450 COUNT	250 SQ FT
Camo Stealthlock	CSL500	900 COUNT	500 SQ FT



Line	Color	165 Plugs, 150 Screws, 1 Tool	
		SKU	Size
Venture	Sandbar	DPLUGSB	100 LF/45 SQ FT
Venture	Saltwater	DPLUGSW	100 LF/45 SQ FT

Line	Color	2-3/4" Deck Screws (100 Count)	
		SKU	Size
Venture	Sandbar	D234BCKSKIN100	100 Pc/30 Sq Ft
Venture	Saltwater	D234GRAY100	100 Pc/30 Sq Ft

Line	Color	2-3/4" Deck Screws (350 Count)	
		SKU	Size
Venture	Sandbar	D234BCKSKIN350	350 Pc/100 Sq Ft
Venture	Saltwater	D234GRAY350	350 Pc/100 Sq Ft

Line	Color	1-7/8" Screws for Risers & Fascia (100 Count)	
		SKU	Size
Venture	Sandbar	DF178BS	30 LF/Riser, 60 LF/Fascia
Venture	Saltwater	DF178GR	30 LF/Riser, 60 LF/Fascia

Hidden Fastener



Cap-Tor® and Epoxy Coated Carbon Steel
100 Microns (1.25")



Cap-Tor® and Epoxy Coated Carbon Steel
100 Microns (1.25")

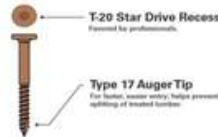

T-20 Star Drive Recess
Fastened by professionals.

Type 17 Auger Tip
For faster, easier entry, helps prevent splitting of treated lumber.

VISTA LINE FASTENERS

Item	SKU	Hidden Fasteners	
		Size	Coverage
Camo Stealthlock	CSL500	90 COUNT	50 SQ FT
Camo Stealthlock	CSL250	450 COUNT	250 SQ FT
Camo Stealthlock	CSL500	900 COUNT	500 SQ FT



Line	Color	165 Plugs, 150 Screws, 1 Tool	
		SKU	Size
Vista	Driftwood	DPLUGKTDWET	100 LF/45 SQ FT
Vista	Ironwood	DPLUGKTIWET	100 LF/45 SQ FT
Vista	Silverwood	DPLUGKTSWDET	100 LF/45 SQ FT
Vista	Dunewood	DPLUGKTDWDET	100 LF/45 SQ FT

Line	Color	2-3/4" Deck Screws (100 Count)	
		SKU	Size
Vista	Driftwood	D234DKSLATE100	100 Pc/30 Sq Ft
Vista	Ironwood	D234CHOC100	100 Pc/30 Sq Ft
Vista	Silverwood	D234GRAY100	100 Pc/30 Sq Ft
Vista	Dunewood	D234BCKSKIN100	100 Pc/30 Sq Ft

Line	Color	2-3/4" Deck Screws (350 Count)	
		SKU	Size
Vista	Driftwood	D234DKSLATE350	350 Pc/100 Sq Ft
Vista	Ironwood	D234CHOC350	350 Pc/100 Sq Ft
Vista	Silverwood	D234GRAY350	350 Pc/100 Sq Ft
Vista	Dunewood	D234BCKSKIN350	350 Pc/100 Sq Ft

Line	Color	1-7/8" Screws for Risers & Fascia (100 Count)	
		SKU	Size
Vista	Driftwood	DF178DS	30 LF/Riser, 60 LF/Fascia
Vista	Ironwood	DF178CL	30 LF/Riser, 60 LF/Fascia
Vista	Silverwood	DF178GR	30 LF/Riser, 60 LF/Fascia
Vista	Dunewood	DF178BS	30 LF/Riser, 60 LF/Fascia



Cap-Tor® and Epoxy Coated Carbon Steel
100 Microns (1.25")



Cap-Tor® and Epoxy Coated Carbon Steel
100 Microns (1.25")



T-20 Star Drive Recess
Fastened by professionals.

Type 17 Auger Tip
For faster, easier entry, helps prevent splitting of treated lumber.

DECKORATORS FASTENERS

SUMMIT LINE FASTENERS

Item	Hidden Fasteners		
	SKU	Size	Coverage
Camo Stealthlock	CSL500	90 COUNT	50 SQ FT
Camo Stealthlock	CSL250	450 COUNT	250 SQ FT
Camo Stealthlock	CSL500	900 COUNT	500 SQ FT



Line	Color	165 Plugs, 150 Screws, 1 Tool	
		SKU	Size
Summit	Glacier	DPLUGTGLAC	100 LF/45 SQ FT
Summit	Cliffside	DPLUGTCLIFF	100 LF/45 SQ FT
Summit	Boulder	DPLUGTBOUL	100 LF/45 SQ FT



Line	Color	2-3/4" Deck Screws (100 Count)	
		SKU	Size
Summit	Glacier	D234GRAY100	100 Pc/30 Sq Ft
Summit	Cliffside	D234SAND100	100 Pc/30 Sq Ft
Summit	Boulder	D234BRN100	100 Pc/30 Sq Ft



Line	Color	1-7/8" Screws for Risers & Fascia (100 Count)	
		SKU	Size
Summit	Glacier	DF178GR	30 LF/Riser, 60 LF/Fascia
Summit	Cliffside	DF178SAND	30 LF/Riser, 60 LF/Fascia
Summit	Boulder	DF178BR	30 LF/Riser, 60 LF/Fascia



Line	Color	2-3/4" Deck Screws (350 Count)	
		SKU	Size
Summit	Glacier	D234GRAY350	350 Pc/100 Sq Ft
Summit	Cliffside	D234SAND350	350 Pc/100 Sq Ft
Summit	Boulder	D234BRN350	350 Pc/100 Sq Ft



VOYAGE LINE FASTENERS

Item	Hidden Fasteners		
	SKU	Size	Coverage
Camo Stealthlock	CSL500	90 COUNT	50 SQ FT
Camo Stealthlock	CSL250	450 COUNT	250 SQ FT
Camo Stealthlock	CSL500	900 COUNT	500 SQ FT



Line	Color	165 Plugs, 150 Screws, 1 Tool	
		SKU	Size
Voyage	Sierra	DPLUGTSSI	100 LF/45 SQ FT
Voyage	Tundra	DPLUGTTU	100 LF/45 SQ FT
Voyage	Mesa	DPLUGTME	100 LF/45 SQ FT
Voyage	Costa	DPLUGTCO	100 LF/45 SQ FT
Voyage	Khaya	DPLUGTKH	100 LF/45 SQ FT
Voyage	Sedona	DPLUGTSE	100 LF/45 SQ FT
Voyage	Dark Slate	DPLUGTDSPE	100 LF/45 SQ FT



Line	Color	2-3/4" Deck Screws (350 Count)	
		SKU	Size
Voyage	Sierra	D234DKGRAY350	350 Pc/100 Sq Ft
Voyage	Tundra	D234WNGRAY350	350 Pc/100 Sq Ft
Voyage	Mesa	D234BRN350	350 Pc/100 Sq Ft
Voyage	Costa	D234TAN350	350 Pc/100 Sq Ft
Voyage	Khaya	D234HOC350	350 Pc/100 Sq Ft
Voyage	Sedona	D234BCKSKIN350	350 Pc/100 Sq Ft
Voyage	Dark Slate	D234DKSLATE350	350 Pc/100 Sq Ft



Line	Color	2-3/4" Deck Screws (100 Count)	
		SKU	Size
Voyage	Sierra	D234DKGRAY100	100 Pc/30 Sq Ft
Voyage	Tundra	D234WNGRAY100	100 Pc/30 Sq Ft
Voyage	Mesa	D234BRN100	100 Pc/30 Sq Ft
Voyage	Costa	D234TAN100	100 Pc/30 Sq Ft
Voyage	Khaya	D234HOC100	100 Pc/30 Sq Ft
Voyage	Sedona	D234BCKSKIN100	100 Pc/30 Sq Ft
Voyage	Dark Slate	D234DKSLATE100	100 Pc/30 Sq Ft



Line	Color	1-7/8" Screws for Risers & Fascia (100 Count)	
		SKU	Size
Voyage	Sierra	DF178DG	30 LF/Riser, 60 LF/Fascia
Voyage	Tundra	DF178WG	30 LF/Riser, 60 LF/Fascia
Voyage	Mesa	DF178BR	30 LF/Riser, 60 LF/Fascia
Voyage	Costa	DF178TAN	30 LF/Riser, 60 LF/Fascia
Voyage	Khaya	DF178CL	30 LF/Riser, 60 LF/Fascia
Voyage	Sedona	DF178BS	30 LF/Riser, 60 LF/Fascia
Voyage	Dark Slate	DF178DS	30 LF/Riser, 60 LF/Fascia

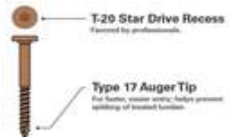

JAMES HARDIE FIBER CEMENT SIDING



James Hardie



**-#1 RETURN ON INVESTMENT EVERY YEAR
SINCE 2005 IN REMODELING MAGAZINE**

-INSTALLED ON OVER 5.5 MILLION HOMES

PRIMED COLLECTION

The primed collection is James Hardie's siding and trim collection in a basic primed finish. Primed collection items are available in a wide variety of substrates.

JAMES HARDIE PRIMED - AVAILABLE SIZES

Primed Plank Siding				
Item	Actual Size	Exposure	Pcs/Square	Unit Size
<i>5.25" Cedarmill Plank</i>	<i>5.25" x 12'</i>	<i>4"</i>	<i>25</i>	<i>360</i>
<i>6.25" Cedarmill Plank</i>	<i>6.25" x 12'</i>	<i>5"</i>	<i>20</i>	<i>308</i>
<i>7.25" Cedarmill Plank</i>	<i>7.25" x 12'</i>	<i>6"</i>	<i>17</i>	<i>252</i>
<i>8.25" Cedarmill Plank</i>	<i>8.25" x 12'</i>	<i>7"</i>	<i>15</i>	<i>230</i>
<i>9.25" Cedarmill Plank</i>	<i>9.25" x 12'</i>	<i>8"</i>	<i>13</i>	<i>190</i>
<i>12" Cedarmill Plank</i>	<i>12" x 12'</i>	<i>10.75"</i>	<i>10</i>	<i>152</i>

<i>5.25" Smooth Plank</i>	<i>5.25" x 12'</i>	<i>4"</i>	<i>25</i>	<i>360</i>
<i>6.25" Smooth Plank</i>	<i>6.25" x 12'</i>	<i>5"</i>	<i>20</i>	<i>308</i>
<i>7.25" Smooth Plank</i>	<i>7.25" x 12'</i>	<i>6"</i>	<i>17</i>	<i>252</i>
<i>8.25" Smooth Plank</i>	<i>8.25" x 12'</i>	<i>7"</i>	<i>15</i>	<i>230</i>
<i>9.25" Smooth Plank</i>	<i>9.25" x 12'</i>	<i>8"</i>	<i>13</i>	<i>190</i>
<i>12" Smooth Plank</i>	<i>12" x 12'</i>	<i>10.75"</i>	<i>10</i>	<i>152</i>

James Hardie Primed Panel Siding				
Item	Actual Size	Thickness	Pcs/Square	Unit Size
<i>4' x 8' Smooth Panel</i>	<i>4' x 8'</i>	<i>5/16"</i>	<i>3.2</i>	<i>50</i>
<i>4' x 9' Smooth Panel</i>	<i>4' x 9'</i>	<i>5/16"</i>	<i>2.8</i>	<i>50</i>
<i>4' x 10' Smooth Panel</i>	<i>4' x 10'</i>	<i>5/16"</i>	<i>2.5</i>	<i>50</i>
<i>16" x 12' Smooth Panel</i>	<i>16"x12'</i>	<i>5/16"</i>	<i>6.3</i>	<i>108</i>
<i>16" x 12' Textured Panel</i>	<i>16"x12'</i>	<i>5/16"</i>	<i>6.3</i>	<i>108</i>

<i>4' x 8' Cedarmill Panel</i>	<i>4' x 8'</i>	<i>5/16"</i>	<i>3.2</i>	<i>50</i>
<i>4' x 9' Cedarmill Panel</i>	<i>4' x 9'</i>	<i>5/16"</i>	<i>2.8</i>	<i>50</i>
<i>4' x 10' Cedarmill Panel</i>	<i>4' x 10'</i>	<i>5/16"</i>	<i>2.5</i>	<i>50</i>

<i>4' x 8' Sierra 8" O.C. Panel</i>	<i>4' x 8'</i>	<i>5/16"</i>	<i>3.2</i>	<i>50</i>
<i>4' x 9' Sierra 8" O.C. Panel</i>	<i>4' x 9'</i>	<i>5/16"</i>	<i>2.8</i>	<i>50</i>
<i>4' x 10' Sierra 8" O.C. Panel</i>	<i>4' x 10'</i>	<i>5/16"</i>	<i>2.5</i>	<i>50</i>

<i>4' x 8' Stucco Panel</i>	<i>4' x 8'</i>	<i>5/16"</i>	<i>3.2</i>	<i>50</i>
<i>4' x 9' Stucco Panel</i>	<i>4' x 9'</i>	<i>5/16"</i>	<i>2.8</i>	<i>50</i>
<i>4' x 10' Stucco Panel</i>	<i>4' x 10'</i>	<i>5/16"</i>	<i>2.5</i>	<i>50</i>

James Hardie Primed Shingles				
Item	Actual Size	Exposure	Pcs/Square	Unit Size
<i>Straight Edge Shingles</i>	<i>48" x 15.25"</i>	<i>7"</i>	<i>43</i>	<i>86</i>
<i>Staggered Edge Shingles</i>	<i>48" x 15.25"</i>	<i>6"</i>	<i>50</i>	<i>100</i>

HardiePlank® Lap Siding
SELECT CEDARMILL



HardiePlank® Lap Siding
SMOOTH



HardiePanel® Vertical Siding
SELECT CEDARMILL



HardiePanel® Vertical Siding
SMOOTH

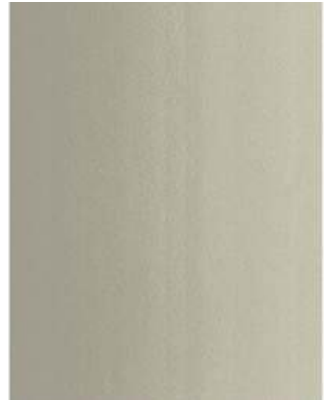

HardiePanel® Vertical Siding
STUCCO



HardiePanel® Vertical Siding
SIERRA 8



HardieShingle® Siding
STAGGERED EDGE PANEL



HardieShingle® Siding
STRAIGHT EDGE PANEL



Features & Benefits:

- #1 Return on Investment every year since 2005 in Remodeling Magazine
- Extremely low maintenance, and provides protection against hail, insects, woodpeckers, and anything else mother nature can throw its way
- Installed on over 5.5 Million homes nationwide
- Protected by James Hardie's 30-year limited warranty

JAMES HARDIE - ARTISAN COLLECTION

The James Hardie Artisan Collections is a unique line of siding profiles that combine the quality and performance of James Hardie, with the craftsman look of classic siding profiles. Artisan is an extremely high performing siding product and very reasonably priced. It can be used for entire exterior siding, gable and dormer accents, as well as porch and patio ceilings and soffits.



Artisan V-Groove



Artisan Shiplap



Artisan Channel



Artisan Lap

Available Sizes:

<i>James Hardie Artisan Siding (Smooth Only)</i>				
Item	Actual Size	Exposure	Pcs/Square	Unit Size
<i>V-Groove Artisan</i>	<i>5/8" x 8.25" x 12'</i>	<i>7"</i>	<i>14</i>	<i>126</i>
<i>Shiplap Artisan</i>	<i>5/8" x 10.25" x 12'</i>	<i>9"</i>	<i>12</i>	<i>105</i>
<i>Square Channel Artisan</i>	<i>5/8" x 10.25" x 12'</i>	<i>9"</i>	<i>12</i>	<i>105</i>
<i>7.25 Lap Artisan</i>	<i>5/8" x 7.25" x 12'</i>	<i>6"</i>	<i>17</i>	<i>144</i>
<i>8.25 Lap Artisan</i>	<i>5/8" x 8.25" x 12'</i>	<i>7"</i>	<i>15</i>	<i>125</i>

Features & Benefits:

- Unique Craftsman Profiles
- Slick blind nail design for hidden fasteners
- Backed by James Hardie's proven performance and 30-year warranty
- Can be mitered for clean professional corners
- Primed and can be painted any color

JAMES HARDIE - EXTERIOR TRIM

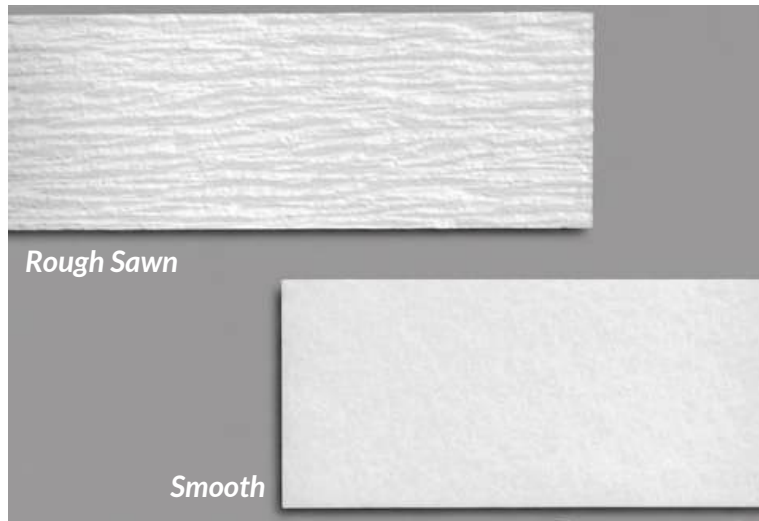

Available Sizes Primed:

Description	Actual Size	Length	Colors	Unit Size
4/4 x 2" Smooth Trim	0.75" x 1.625"	12'	Primed	405
4/4 x 2.5" Smooth Batten	0.75" x 2.5"	12'	Primed	437
4/4 x 4" Smooth Trim	0.75" x 3.5"	12'	Primed	322
4/4 x 6" Smooth Trim	0.75" x 5.5"	12'	Primed	184
4/4 x 8" Smooth Trim	0.75" x 7.25"	12'	Primed	138
4/4 x 10" Smooth Trim	0.75" x 9.25"	12'	Primed	115
4/4 x 12" Smooth Trim	0.75" x 11.25"	12'	Primed	92
4/4 x 2" Rough Sawn Trim	0.75" x 1.625"	12'	Primed	405
4/4 x 2.5" Rough Sawn Batten	0.75" x 2.5"	12'	Primed	437
4/4 x 4" Rough Sawn Trim	0.75" x 3.5"	12'	Primed	322
4/4 x 6" Rough Sawn Trim	0.75" x 5.5"	12'	Primed	184
4/4 x 8" Rough Sawn Trim	0.75" x 7.25"	12'	Primed	138
4/4 x 10" Rough Sawn Trim	0.75" x 9.25"	12'	Primed	115
4/4 x 12" Rough Sawn Trim	0.75" x 11.25"	12'	Primed	92

JAMES HARDIE - BACKER



HardieBacker® cement board is a tile underlayment made to use with floors and countertops.

Works in kitchens, bathrooms, or other areas within the home, especially useful for tiling.

The cement boards are made of 90% Portland cement and sand which resists damage from moisture and provides excellent tile adhesion. Product formulation results in a combination of strength, uniform composition, and performance. HardieBacker® cement board is easier to use, cuts with tight seam lines, and less debris. HardieBacker® contains superior strength and durability delivering a solid foundation in projects involving tile, flooring, and stone countertops.

Available Sizes:

In Stock - Warehouse Items

Thickness	Size	Unit Size
<i>1/4"</i>	<i>3' x 5'</i>	<i>60</i>
<i>1/2"</i>	<i>3' x 5'</i>	<i>50</i>

EASYTRIM REVEALS



EasyTrim Reveals® are a two-piece aluminum trim system that snaps together to protect your siding. Compatible with a wide range of siding solutions, EasyTrim Reveals® will save you time during installation while providing best-in-class weather protection and durability for the future.

EasyTrim works best with James Hardie panel siding and provides for a fast and simple installation that provides best-in-class water management, hidden fastening, and NO CAULKING. Builders and developers love EasyTrim because it simply works. It's easy to install, it saves their crews time, and it looks great.

Features & Benefits:

EZ Bump

- Revolutionary water-management meets clean fit and finish
- Intelligently designed drainage channels slot together neatly for tidy appearance

Dirt and Water Management

- 8 degree EZ Slope that properly cycles moisture out and away
- Sheds water and expels dirt and debris

Quick and easy installation

- All pieces are either a singular pre-formed trim or a simple two-piece snap installation
- Seamlessly installs with James Hardie panels
- Provides full panel coverage (length and width), so no field cutting is required for full panel sections

Fit and Finish

- Sharp, modern, clean look
- No sharp edges
- Trims interlock creating smooth terminations

EASYTRIM REVEALS

FIBER CEMENT 5/16" PANEL TRIM SYSTEM

OUTSIDE CORNERS						INSIDE CORNERS	
EZ 1	EZ 2	EZ 12	EZ 13 ✓	EZ 14 ✓	EZ 15	EZ 3 ✓	EZ 18
1-Piece Square Outside Corner 5/16" Panel Trim	Round Outside Corner 5/16" Panel Trim	2-Piece Square Outside Corner 5/16" Panel Trim	Arrow Outside Corner 5/16" Panel Trim	4-Piece Outside Corner 5/16" Panel Trim	Multi-Angle Outside Corner 5/16" Panel Trim (105°-145°)	Inside Corner 5/16" Panel Trim	Multi-Angle Inside Corner 5/16" Panel Trim (90°-165°)
HORIZONTAL TRIMS			J TRIMS				
EZ 4 ✓	EZ 5 ✓	EZ 10 ✓	EZ 8 ✓	EZ 9 ✓	EZ 20	EZ 21	
Horizontal 2 5/16" Panel Trim	Horizontal Revealed 5/16" Panel Trim	Horizontal Bead 5/16" Panel Trim	General J 5/16" Panel Trim	Soffit J 5/16" Panel Trim	2-Piece General J 5/16" Panel Trim	2-Piece Soffit J 5/16" Panel Trim	
VERTICAL 2-PIECE TRIM		SOFFIT TRIM	SLT TRIMS				
EZ 7 ✓	EZ 19	EZ 29	EZ 22	EZ 23	EZ 24		
2-Piece Vertical J 5/16" Panel Trim	2-Piece Vertical Window Jamb 5/16" Panel Trim	Perforated Soffit 5/16" Panel Trim	Horizontal SLT 2 5/16" Panel Trim	2-Piece Vertical SLT 5/16" Panel Trim	2-Piece Window SLT 5/16" Panel Trim		

FIBER CEMENT 3/4" LAP TRIM SYSTEM

OUTSIDE CORNERS				INSIDE CORNERS		VERTICAL TRIM
EZ 31	EZ 33	EZ 34 ✓	EZ 35	EZ 36 ✓	EZ 37	EZ 38
1-Piece Square Outside Corner 3/4" LAP Trim	Arrow Outside Corner 3/4" LAP Trim	X-Outside Corner 3/4" LAP Trim	Multi-Angle Outside Corner 3/4" LAP Trim (105°-165°)	Inside Corner 3/4" LAP Trim	Multi-Angle Inside Corner 3/4" LAP Trim (90°-165°)	2-Piece Vertical J 3/4" LAP Trim
J TRIM		HORIZONTAL TRIM				
EZ 40 ✓	EZ 48 ✓					
General J 3/4" LAP Trim	Horizontal Bead 2 3/4" LAP Trim					

EASYTRIM REVEALS

FIBER CEMENT 5/16" TO 3/4" TRANSITION TRIMS

OUTSIDE CORNERS		INSIDE CORNER		VERTICAL 2-PIECE TRIM
EZ 16	EZ 45	EZ 17	EZ 46	EZ 11
2-Piece Outside Corner 5/16" to 3/4" Transition Trim	Multi-Angle Outside Corner 5/16" to 3/4" Transition Trim (20P-1687)	Inside Corner 5/16" to 3/4" Transition Trim	Multi-Angle Inside Corner 5/16" to 3/4" Transition Trim (20P-1687)	2-Piece Vertical U 5/16" to 3/4" Transition Trim

UNIVERSAL TRIMS

WINDOW FLASHING	STARTER TRIM
EZ 28	EZ 60
1/2" Window Sill Cap Flashing	Perforated Vented Starter Strip Trim (Vinyl)

FIBER CEMENT 7/16" PANEL TRIM SYSTEM

OUTSIDE CORNER	INSIDE CORNER	HORIZONTAL TRIMS			VERTICAL 2-PIECE TRIM	J TRIMS	
EZ 62	EZ 63	EZ 64	EZ 65	EZ 70	EZ 67	EZ 68	EZ 71
2-Piece Square Outside Corner 7/16" Panel Trim	2-Piece Inside Corner 7/16" Panel Trim	Horizontal Z 7/16" Panel Trim	Horizontal H 7/16" Panel Trim	Horizontal Base B 7/16" Panel Trim	2-Piece Vertical U 7/16" Panel Trim	General J 7/16" Panel Trim	2-Piece General J 7/16" Panel Trim

FIBER CEMENT 1" LAP TRIM SYSTEM

OUTSIDE CORNERS		INSIDE CORNER	HORIZONTAL TRIM	J TRIM	VERTICAL 2-PIECE TRIM
EZ 83	EZ 84	EZ 85	EZ 81	EZ 80	EZ 82
Arched Outside Corner 1" LAP Trim	X Outside Corner 1" LAP Trim	Inside Corner 1" LAP Trim	Horizontal Base Z 1" LAP Trim	General J 1" LAP Trim	2-Piece Vertical U 1" LAP Trim

MIRATEC EXTERIOR TRIM



Available Sizes:

Item	Actual Size	Lengths	Unit Size	Finish
5/8 x 4	0.63" x 3.5"	16'	240	Primed
5/8 x 6	0.63" x 5.5"	16'	160	Primed
5/8 x 12	0.63" x 11.25"	16'	80	Primed
1 x 2	0.75" x 2"	16'	168	Primed
1 x 4	0.75" x 3.5"	16'	144	Primed
1 x 6	0.75" x 5.5"	16'	96	Primed
1 x 8	0.75" x 7.25"	16'	72	Primed
1 x 12	0.75" x 11.25"	16'	48	Primed
5/4 x 4	1" x 3.5"	16'	108	Primed
5/4 x 6	1" x 5.5"	16'	72	Primed
5/4 x 12	1" x 11.25"	16'	36	Primed

Features & Benefits:

- Resists moisture, rot, and termites
- Handles like regular wood - easy to cut, position, and nail
- Backed by an industry best 50-year warranty
- Half the cost of PVC and premium composites
- Pairs with any siding: vinyl, fiber cement, panels, and wood siding
- Smaller unit sizes for quicker turns

LITEBAR GFRP REBAR



Available Sizes:

Item ID	Steel Equiv.	Description	Thickness	Length	Weight/PC (LBS)	Bundle Size	Unit Size
5162GFRP	3/8"	5/16" x 20' Rebar	5/16"	20'	1.60	50 PIECE	500
7162GFRP	1/2"	7/16" x 20' Rebar	7/16"	20'	2.55	50 PIECE	500
9162GFRP	5/8"	9/16" x 20' Rebar	9/16"	20'	3.70	25 PIECE	250

Features & Benefits:

- Rust Free, does not corrode, extended structure life
- Lightweight, large labor & freight savings
- Non-conductive, LiteBar is electrically non-conductive and thermally non-conductive
- Stronger than steel, LiteBar is 2x stronger than steel in tensile strength
- Installs like steel, toe it off and chair it up just like steel

Applications:

- Driveways and walkways
- Foundation footings
- Grain bins and barns
- Pool decks
- Patios and porches



BENDER BOARD CONCRETE FORM



Available Sizes:

Item	Thickness	Size	Unit Size	Species
<i>6" x 16' Bender Board</i>	<i>1/4"</i>	<i>6" x 16'</i>	<i>400</i>	<i>Hardboard</i>
<i>12" x 16' Bender Board</i>	<i>1/4"</i>	<i>12" x 16'</i>	<i>200</i>	<i>Hardboard</i>

Features & Benefits:

- Flexible and bendable for curves, radiuses, and bends
- Full 16' length
- Hardboard surface for a smooth matte concrete finish
- Competitively priced and very affordable

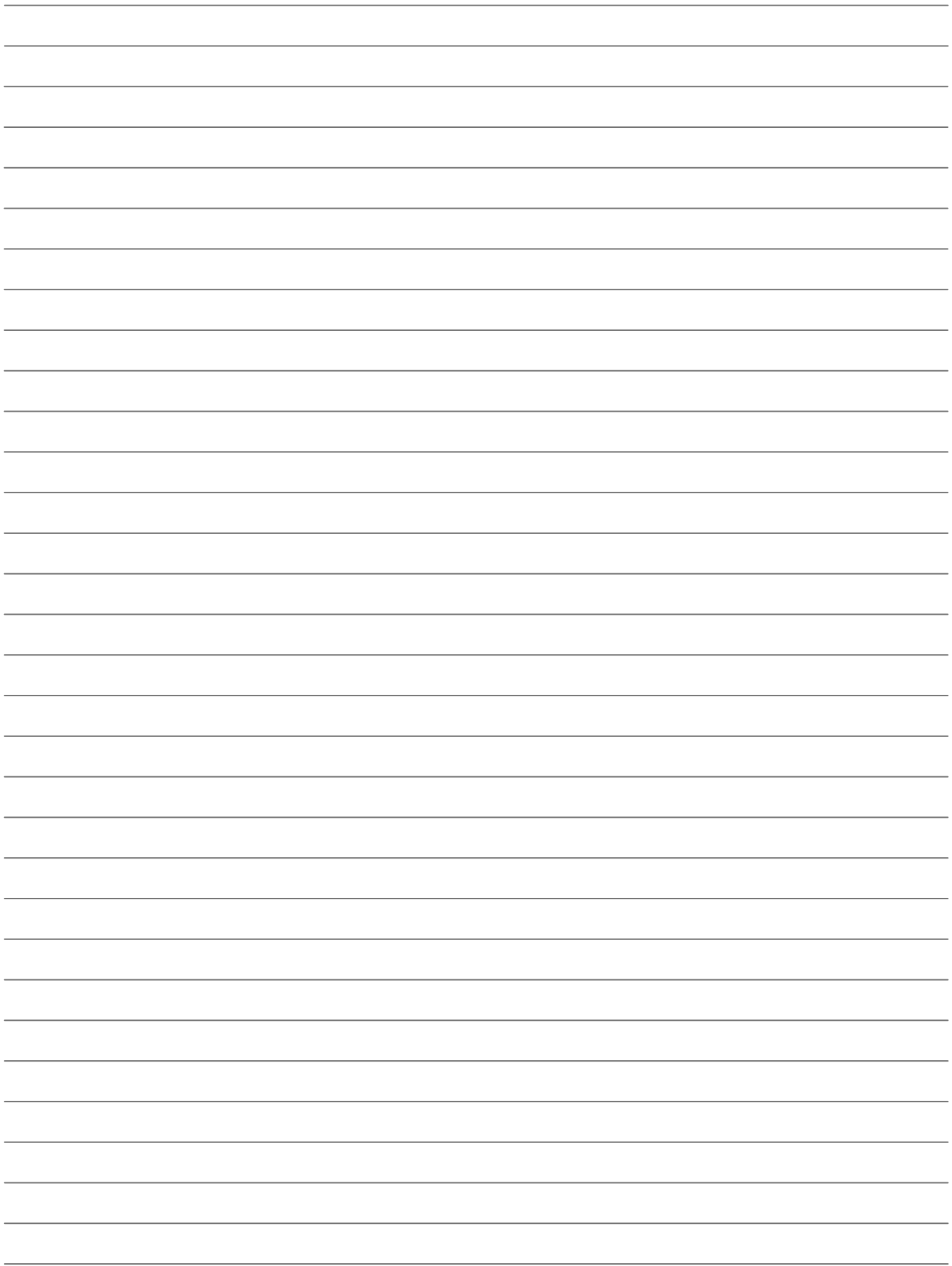



855.875.7188

8700 S I-35 Service Rd. Oklahoma City, OK 73149

www.fp-supply.com